

Datang Mobile

&

TD-SCDMA

Guiliang YANG

June 10, 2005

- **Company Overview**
- **TD-SCDMA Solution**
 - **Technology and Standard**
 - **Solution and Product**
 - **Progress**

About us

Overview of Datang Group

- One of key players in China's telecommunications industry with broad range of product sections
- Previous CATT (China Academy of Telecommunication Technology)
- Including 2 listing companies, 7 Joint venture\share-holding companies and 8 research institute
- With more than 10,000 employees, 70% of which are engineers;



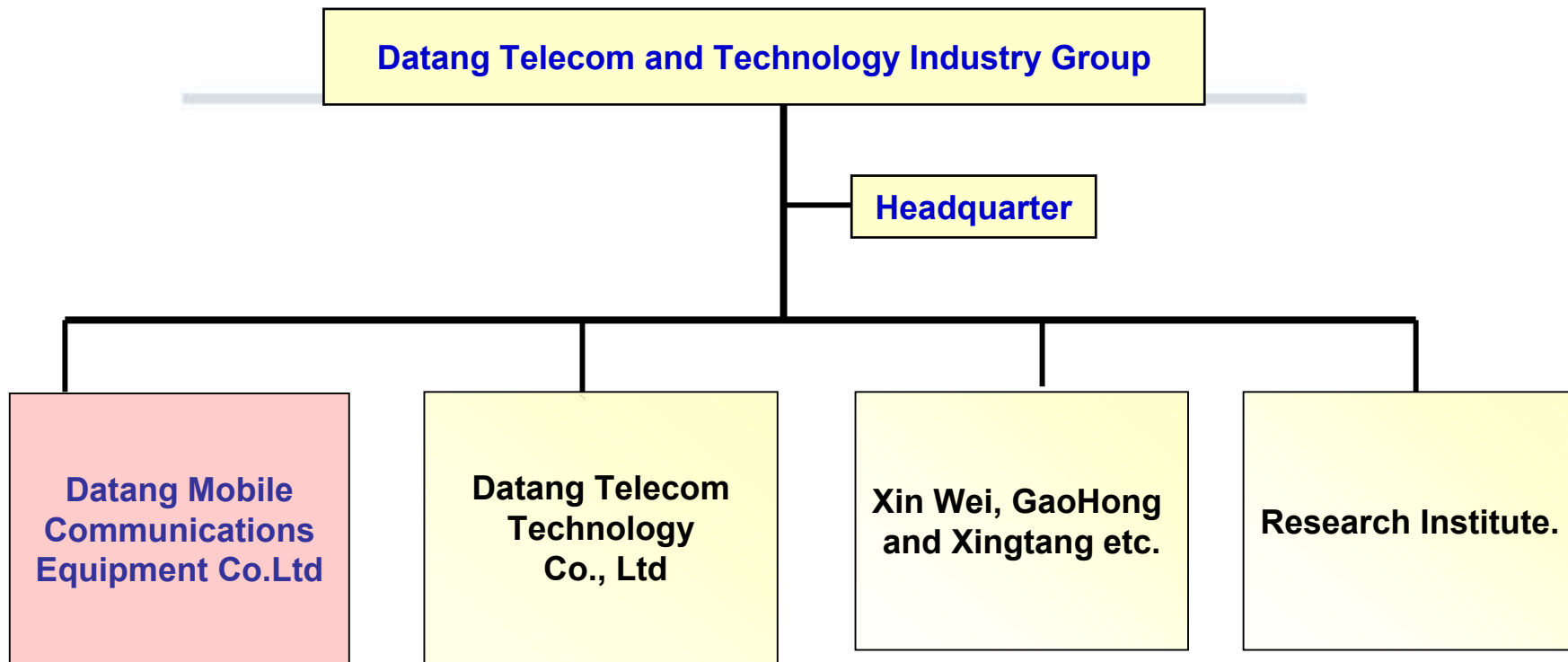

- Established on February, 2002 consolidating all the mobile assets within the Group
- Focusing on developing 3G and further wireless solution, providing TD-SCDMA products and service
- A leading company in TD-SCDMA industry

Core TD-SCDMA
Technology

Experienced
Team



Industry
Resource

Business
relationships

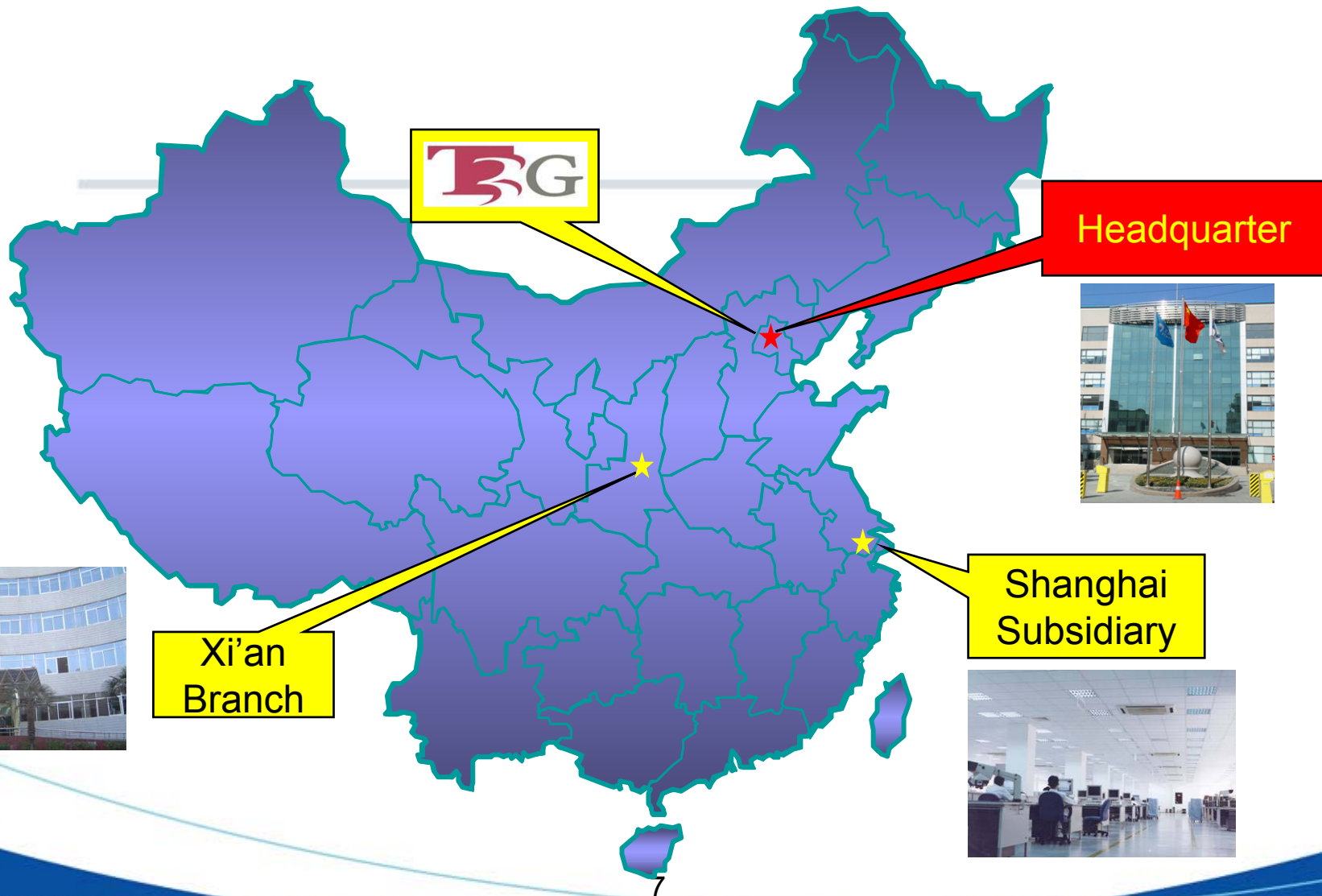

Enable TD-SCDMA to Success

Technology

We provide the innovative and qualified technology and IPR to help TD-SCDMA manufactures success...



Product

We provide the best TD-SCDMA total solution to facility operators and manufactures



Service

Professional services on-demand



Standard and Technology

- **Technology and Standard**
- **Solution and Product**
- **Progress**

International 3G Standard

☞ 3G Technology: CDMA

- TDD Mode: TD-SCDMA (China), UTRA-TDD (Europe)
- FDD Mode: WCDMA (Europe & Japan), CDMA2000 (U.S.)

☞ **TD-SCDMA, is the sole TDD product with the potential in mass commercialization in China.**

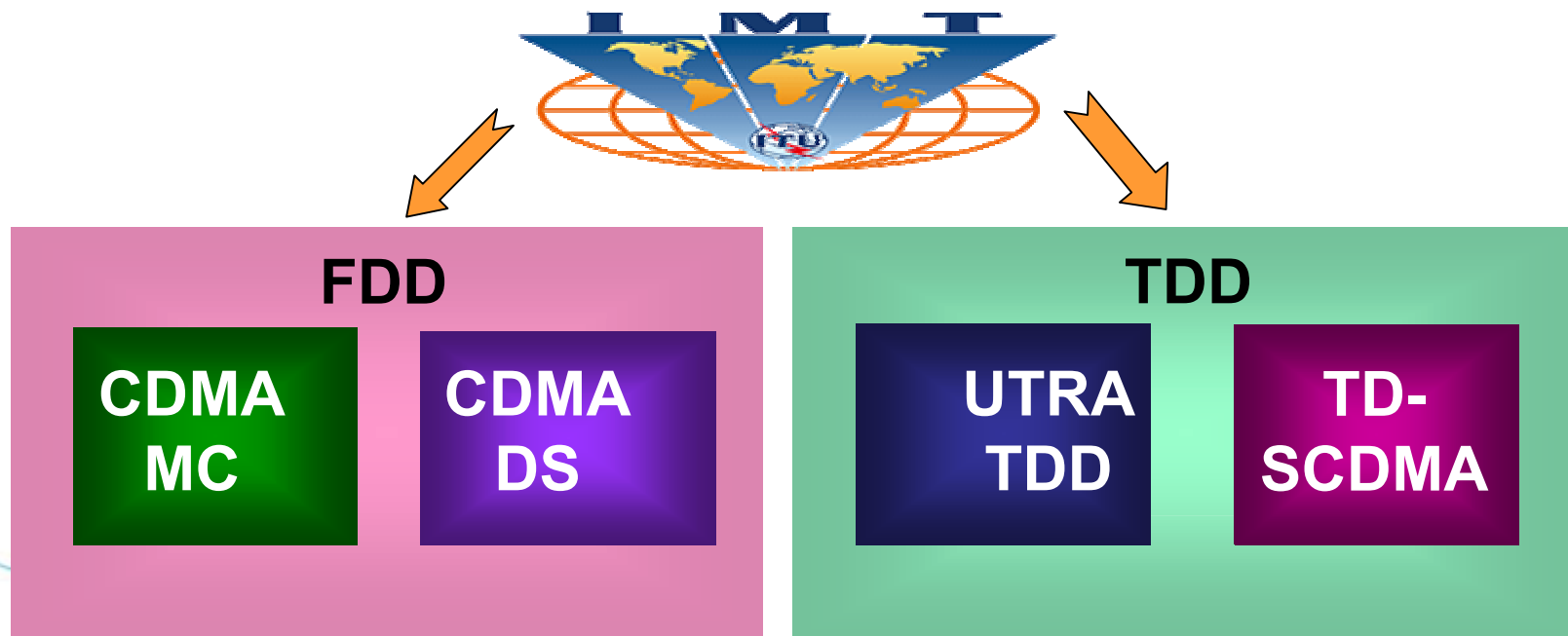

TD-SCDMA Standard

- **ITU acceptance in 1998 and approval in WRC2000**
- **Harmonization with UMTS on CN and architecture**
- **Included in 3GPP from R'4 (2001) to R'7(now)**
- **Specifications fixed and mature for R'4/5,**
- **New features and technologies introduced after R'5 and LTE**
- **Has the characteristics for Beyond 3G defined in ITU**

What is TD-SCDMA

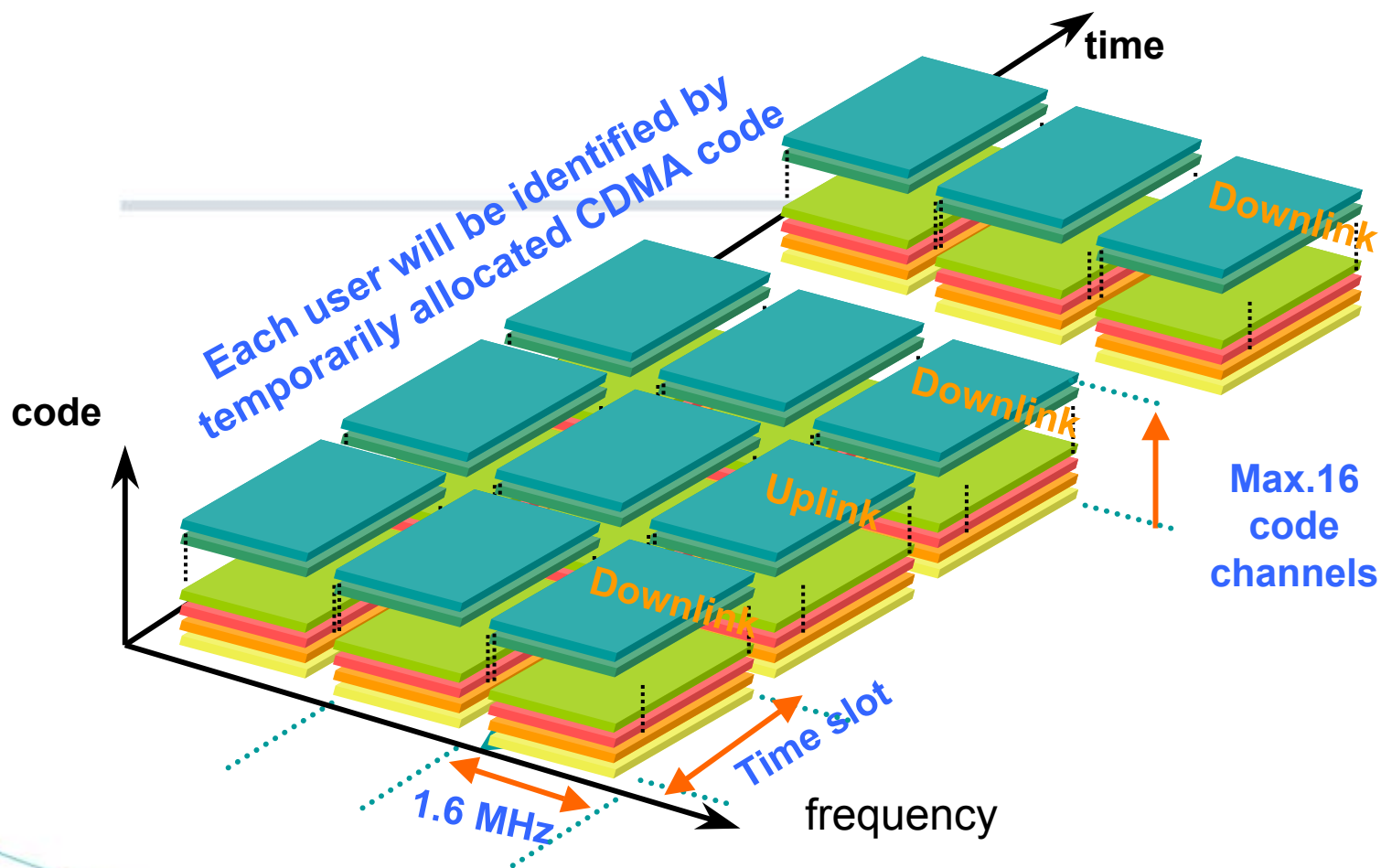

Combined with the advantages of CDMA、TDMA、FDMA
Spectrum efficiency and anti-interference capability

3GPP TDD vs. FDD

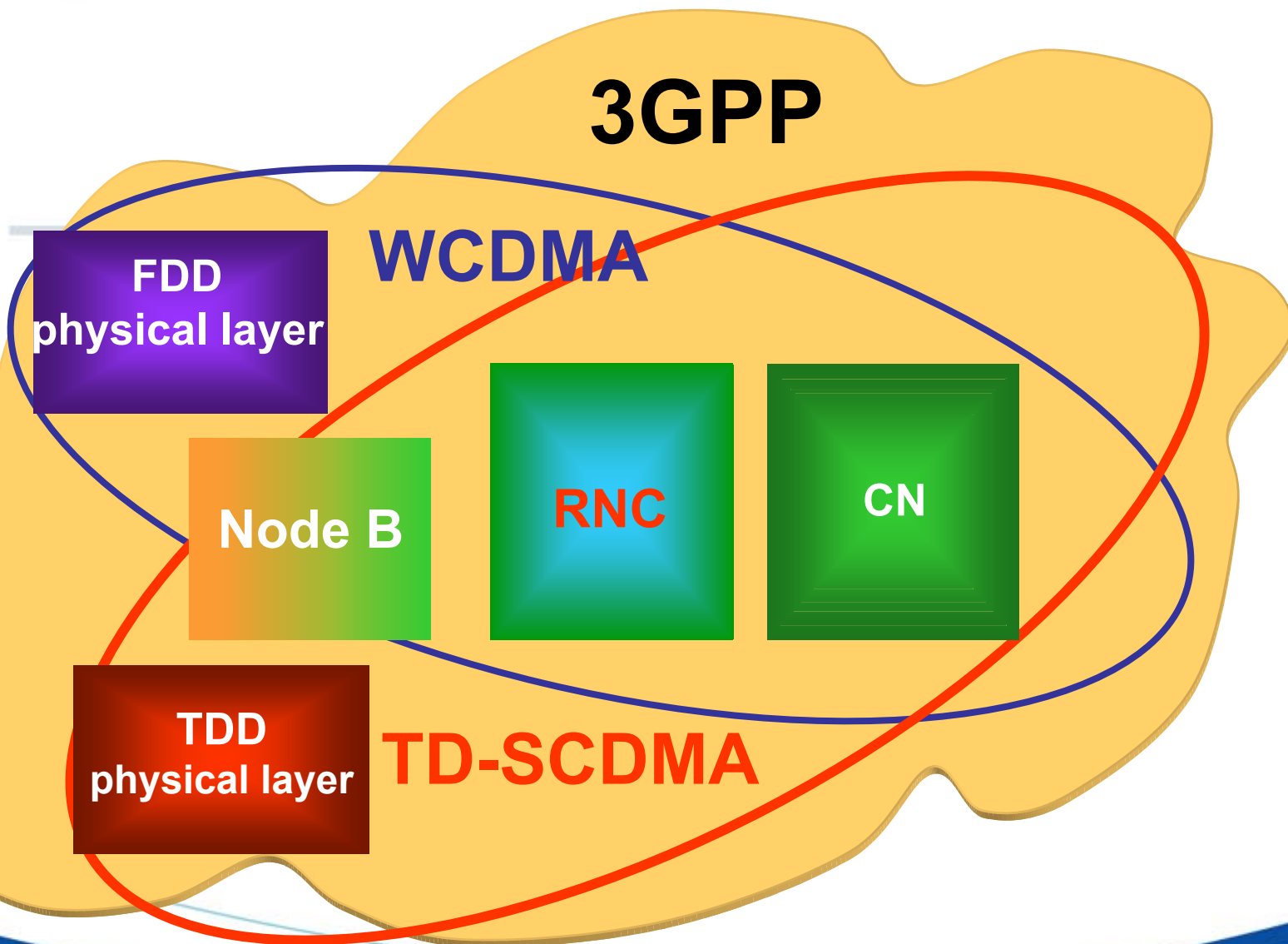

TD-SCDMA Key Technologies

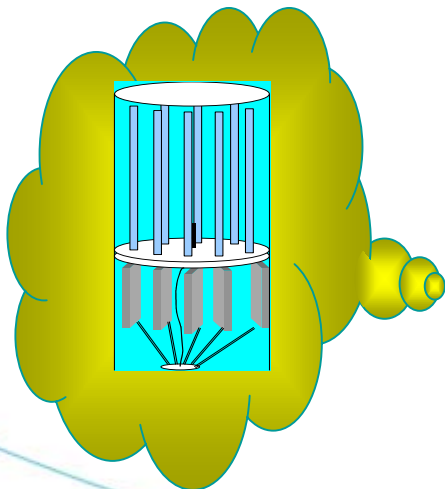
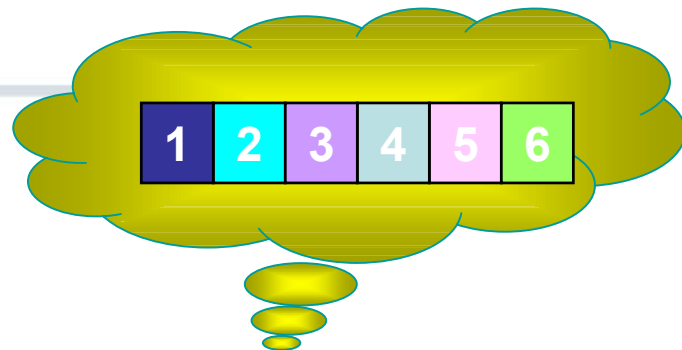
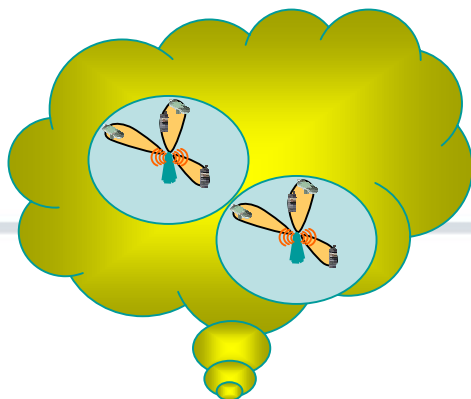
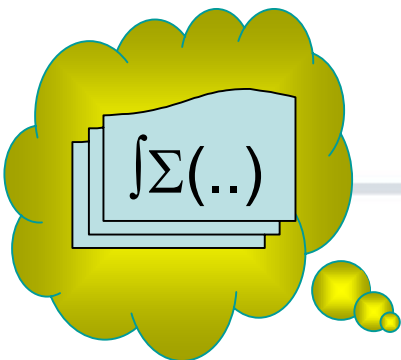

- TDD duplex
- Smart Antenna (SA)
- Joint Detection (JD)
- Uplink Synchronization
- Baton Handover
- Dynamic Channel Allocation (DCA)

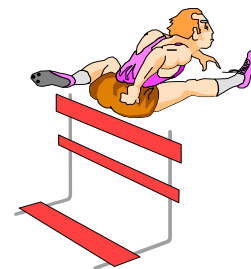
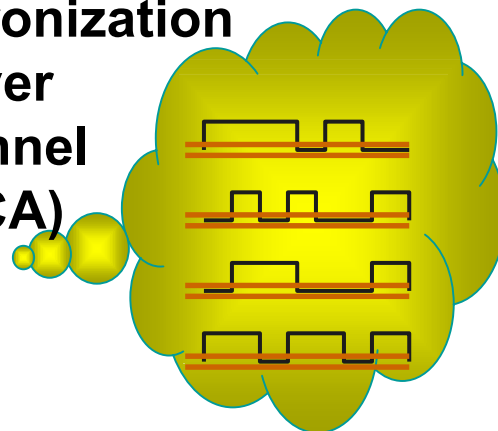

TDD duplex

- UL/DL share the same frequency on time slots
- Switch point for UL/DL flexible for (a)symmetric services
- The similar radio channel environment for UL/DL for easy adoption of technologies e.g. SA
- Unpaired band

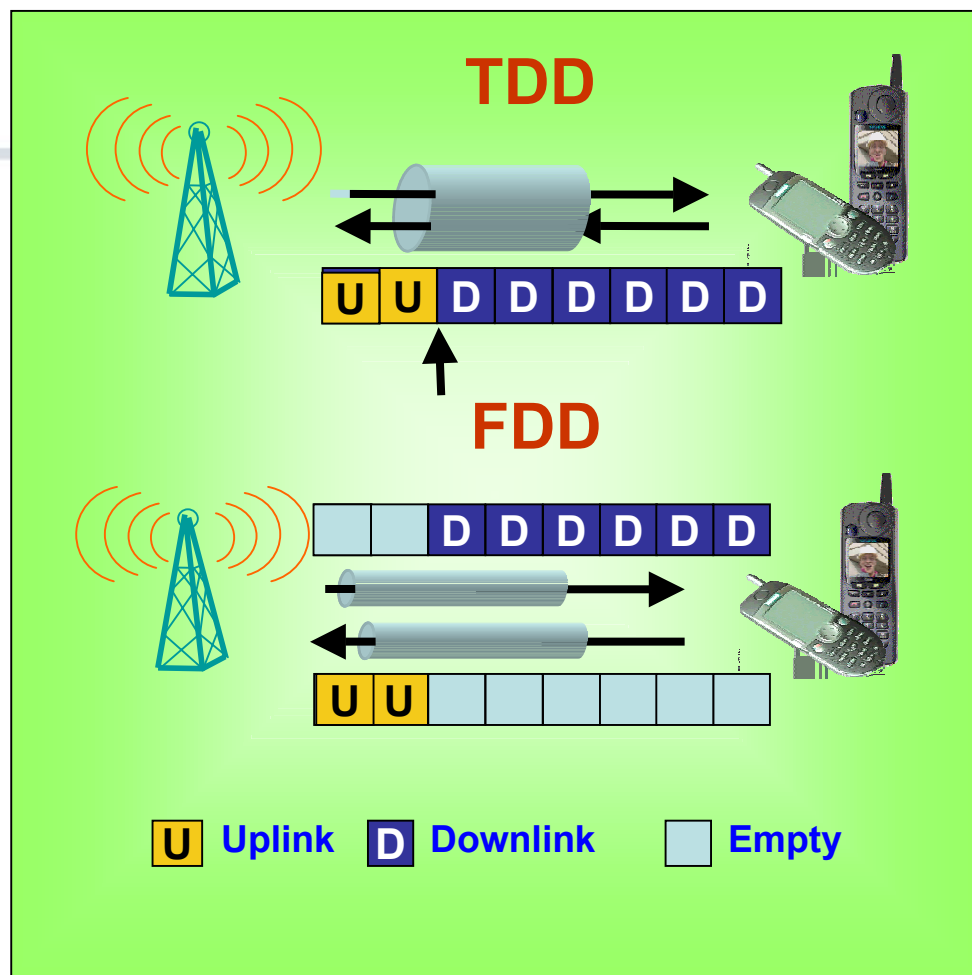

Smart Antenna

- **With Smart Antenna ...**
 - Directional TX and RX
 - UE is tracked during connection
- **W/O Smart Antenna ...**
 - Omni-directional TX and RX
 - interference from/to adjacent cells
- **The advantages of SA**
 - Minimizing inter/intra-cell interference
 - Effective TX power
 - Improved receiving sensitivity
 - Increased coverage and capacity
 - Reduced Node B cost for RF

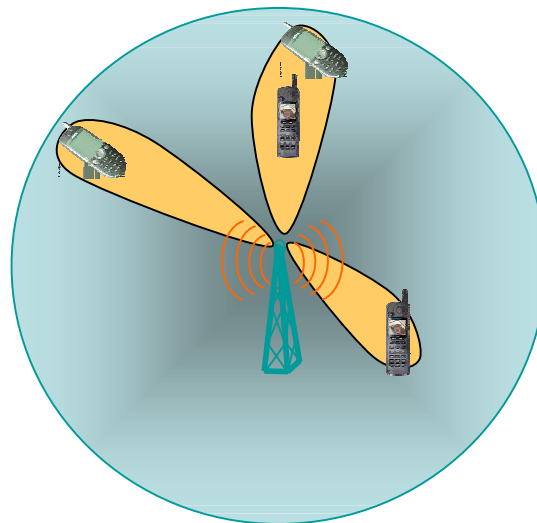
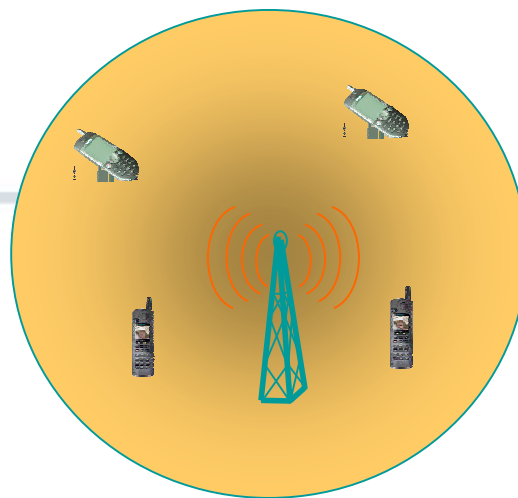

Joint Detection

- MAI is the major interference in the CDMA system.
- Traditional signal processing to deal MAI as noise
- JD optimizes the specific user signal, including:
 - Specific user signal channel code
 - Specific training sequence
- Process all the signals in parallel to eliminate MAI

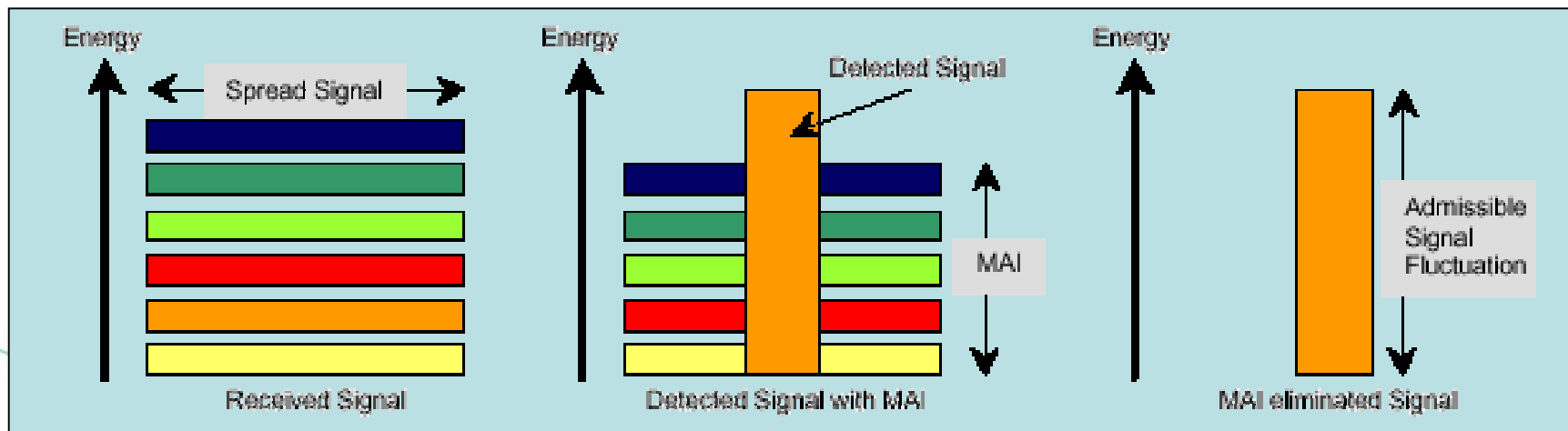

Synchronized CDMA

- UL signals from UE arrived the NodeB synchronized
- Minimized MAI to simplified signal processing on Node B, and to reduce the cost
- Including establishment, dynamic maintenance of synchronization, and the accurate tracking control

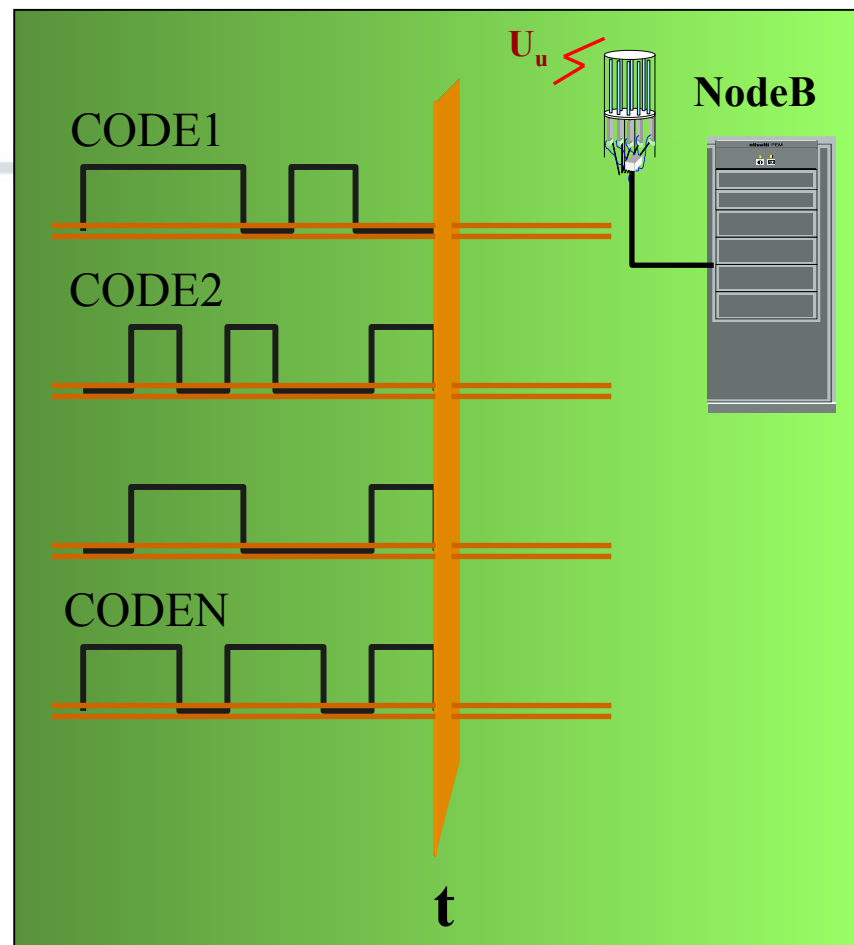

Baton Handover

- UE hand over with pre UL sync and stepped switch for UL/DL
- Less channel occupation compared with soft hand over
- Shorter switch gap and higher reliability compared with hard hand over

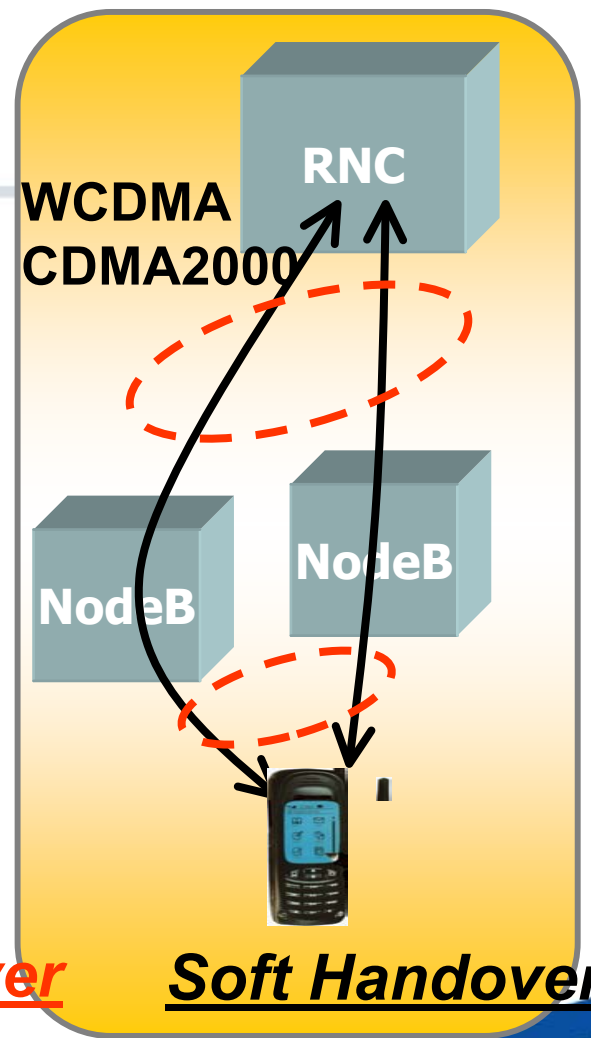
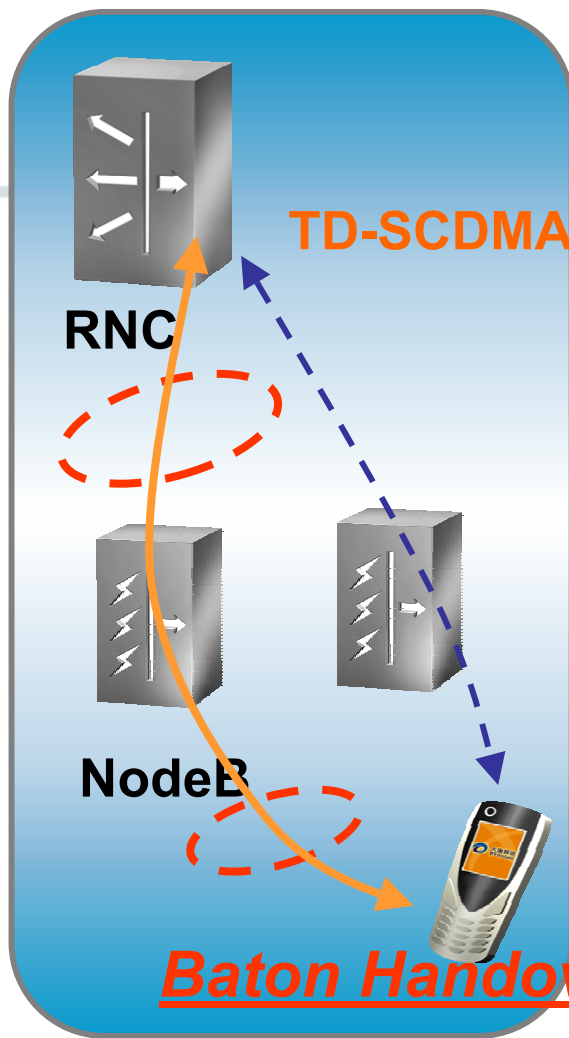

Dynamic Channel Allocation

- Optimal and adaptive allocation of the radio resources according to the interference scenario
- DCA aspects include:
 - Code domain: spreading code
 - Time domain: time slots
 - Space domain: beam forming
 - Frequency domain: carrier

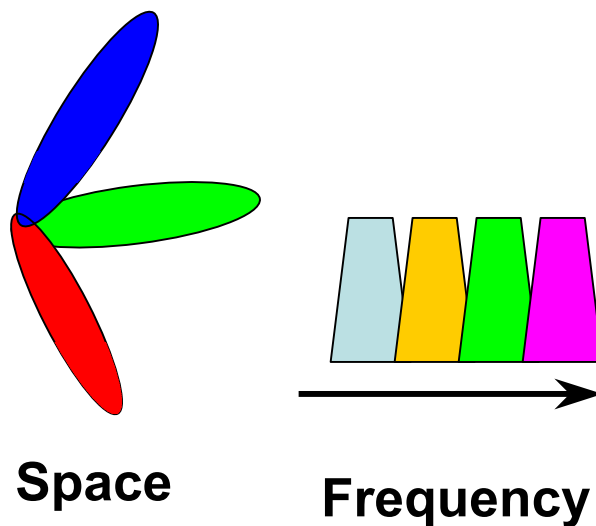
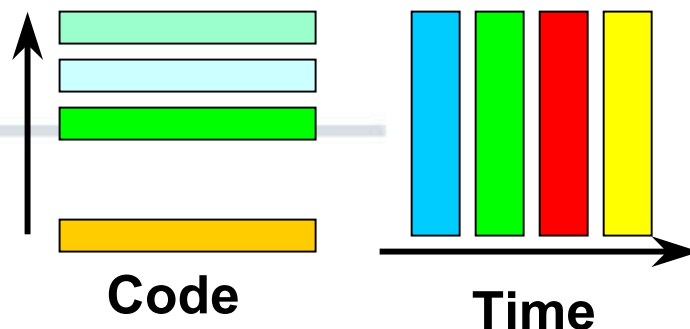

Advantages of TD-SCDMA

- With its key features, TD-SCDMA has become the most competitive in the international 3G standard.
- TD-SCDMA can help improve the competitiveness of operators and the rich application for the users.
- Powerful data application enables TD-SCDMA the most promising 3G technology.

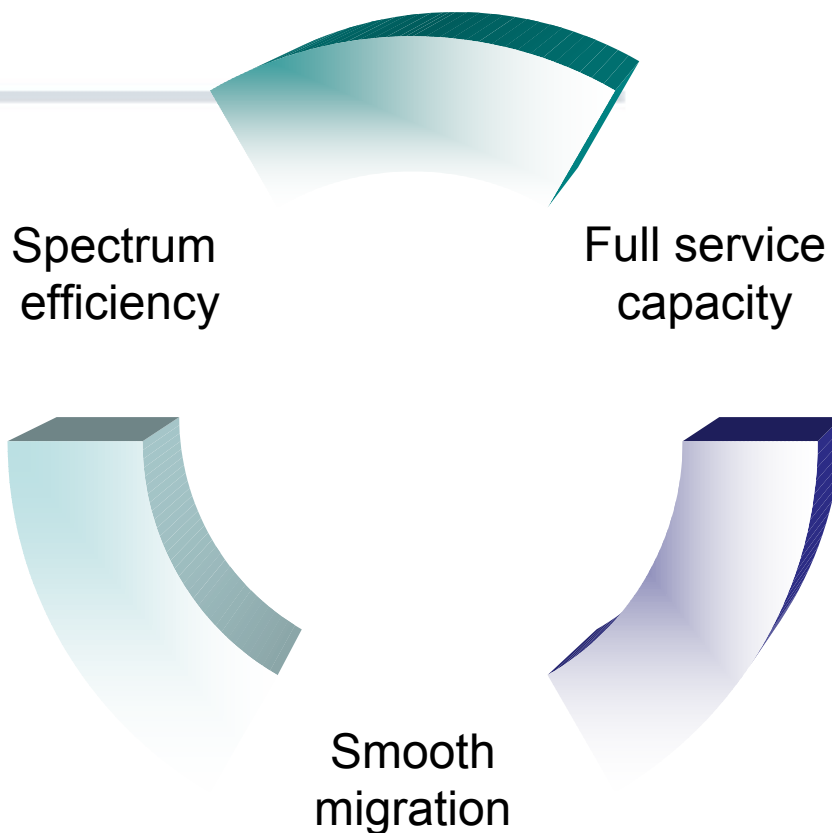

- **Technology and Standard**
- **Solution and Product**
- **Progress**

TD-SCDMA Network

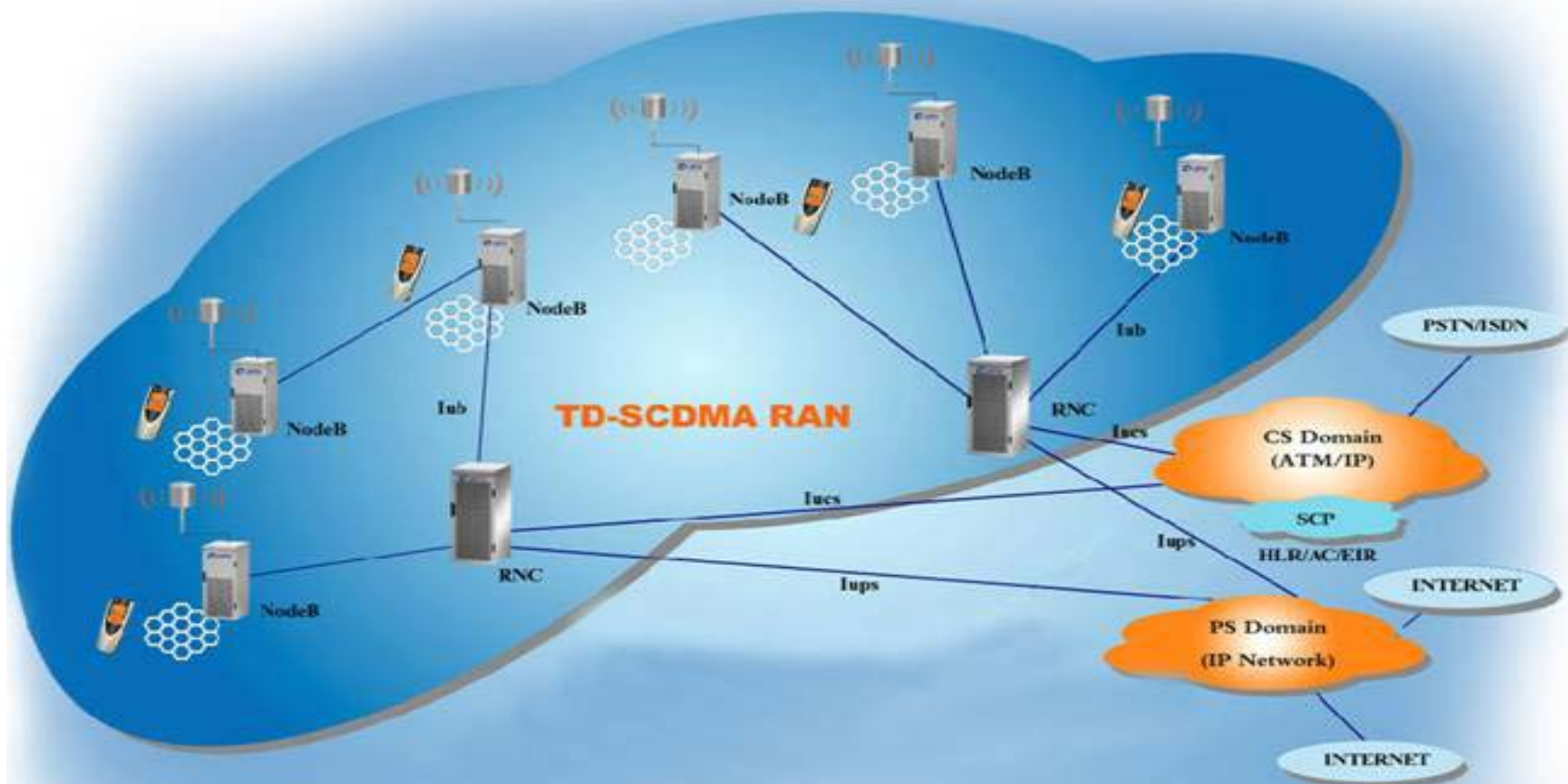

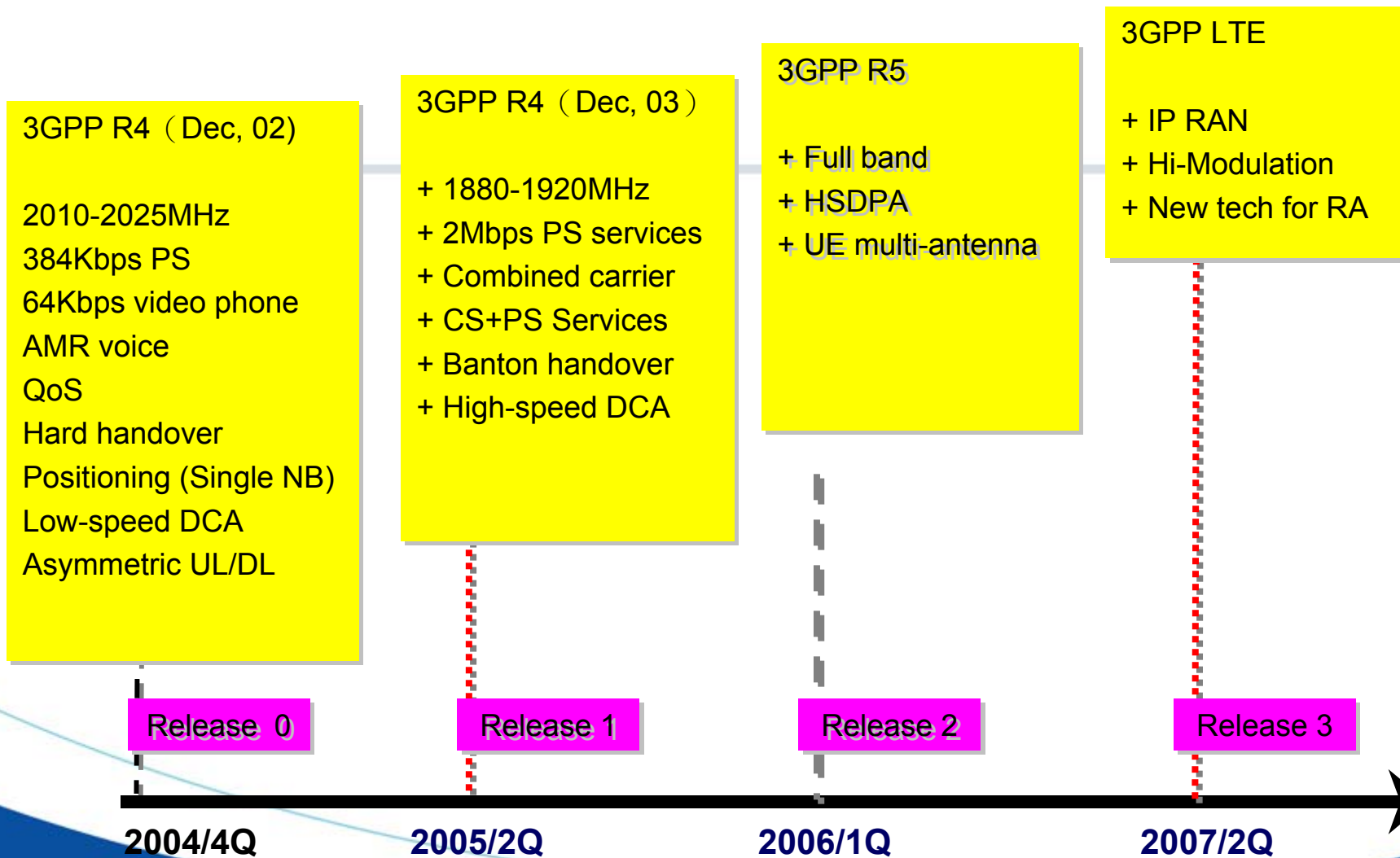

Roadmap

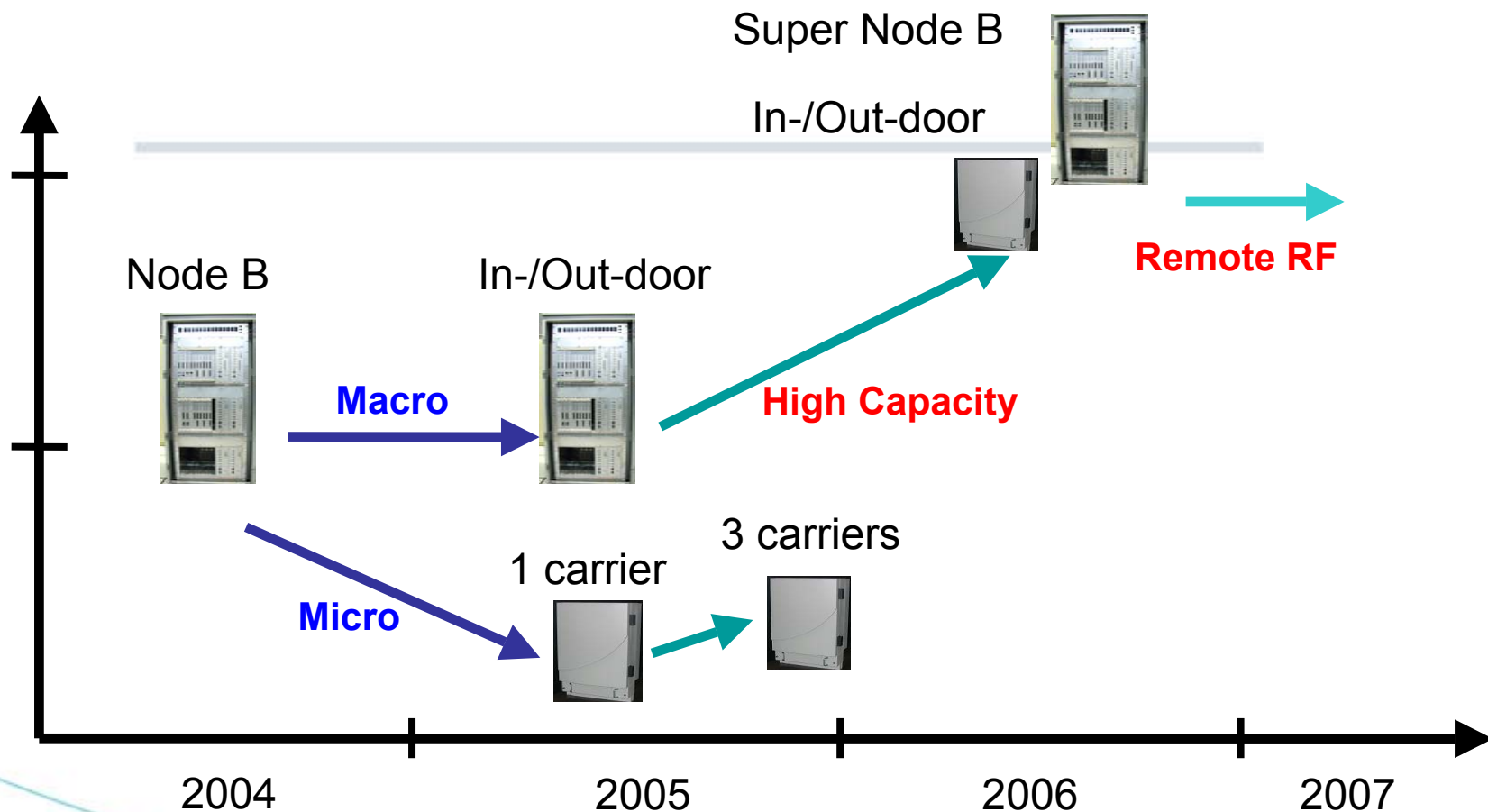

Node B Products Roadmap



Node B Products

	Main parameters	Senario
<p>Macro NB (indoor/outdoor)</p> 	<ul style="list-style-type: none"> • Maximal capacity: 3C3S • Omnidirected/sector smart antenna • 2010-2025/1880-1920MHz • Iub supporting STM-1 or E1 interface • Star, chain, and loop connection 	<ul style="list-style-type: none"> • Highly populated urban area • common urban area • suburbs • rural area • traffic lines
<p>Micro NB</p> 	<ul style="list-style-type: none"> • Maximal capacity: 3C • Omnidirected/sector antenna • 2010-2025/1880-1920MHz • Iub supporting STM-1 or E1 interface • Star, chain connection 	<ul style="list-style-type: none"> • indoor • coverage enhancement • rural area • traffic lines

RNC

Parameters	1 frame	4 frame
Processing Capacity (Erl.)	3,564	32,076
Data transmission capacity (bps)	256M	2G
Maximal E1 connectors	256	2,048
Maximal STM-1 connectors	48	196
Maximal Node B	192	1,782
Maximal cells	192	1,782
Users	120,000	1,060,000
BHCA	200k	1,800k

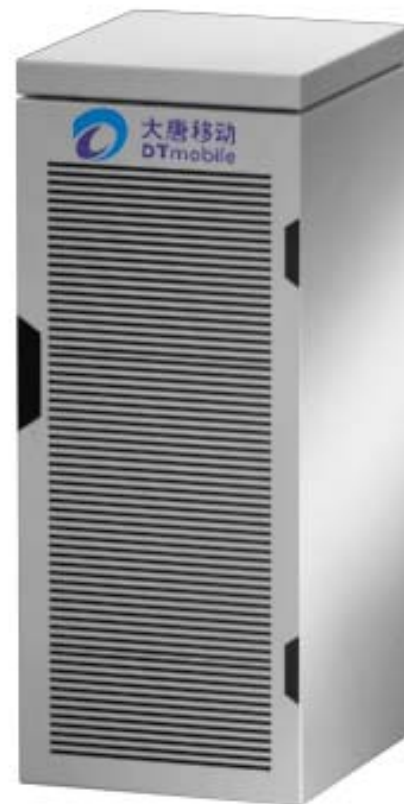

- OMC-R terminal
- OMC-R Server
- Protocol gateway
- OMC interface
- Database server

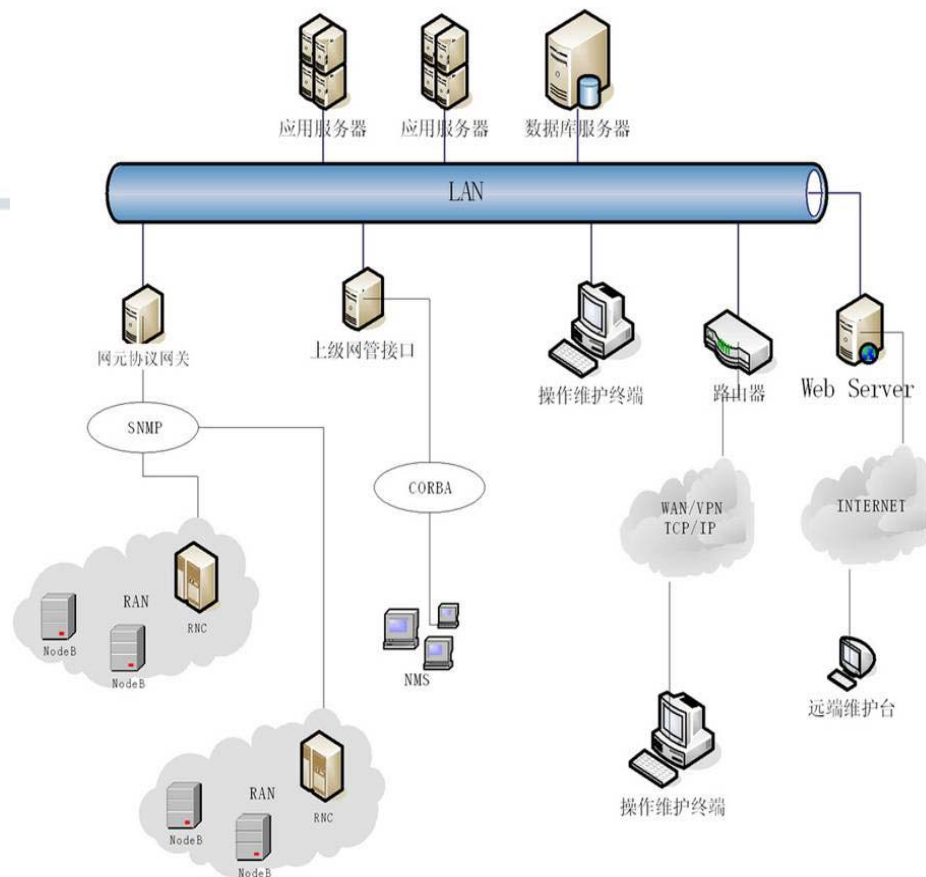

Planning and Optimization



Planning

Optimizing

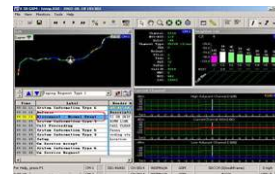
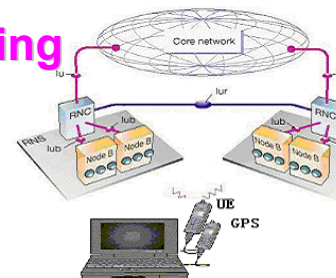

Data collecting software Analyzing software

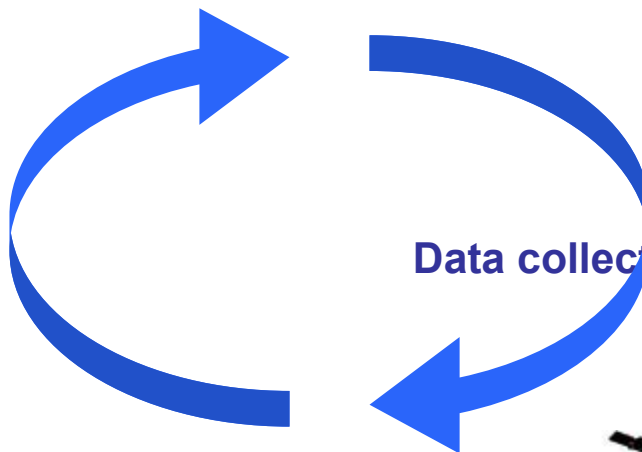

Field test products



- **Technology and Standard**
- **Solution and Product**
- **Progress**

TD-SCDMA Tests

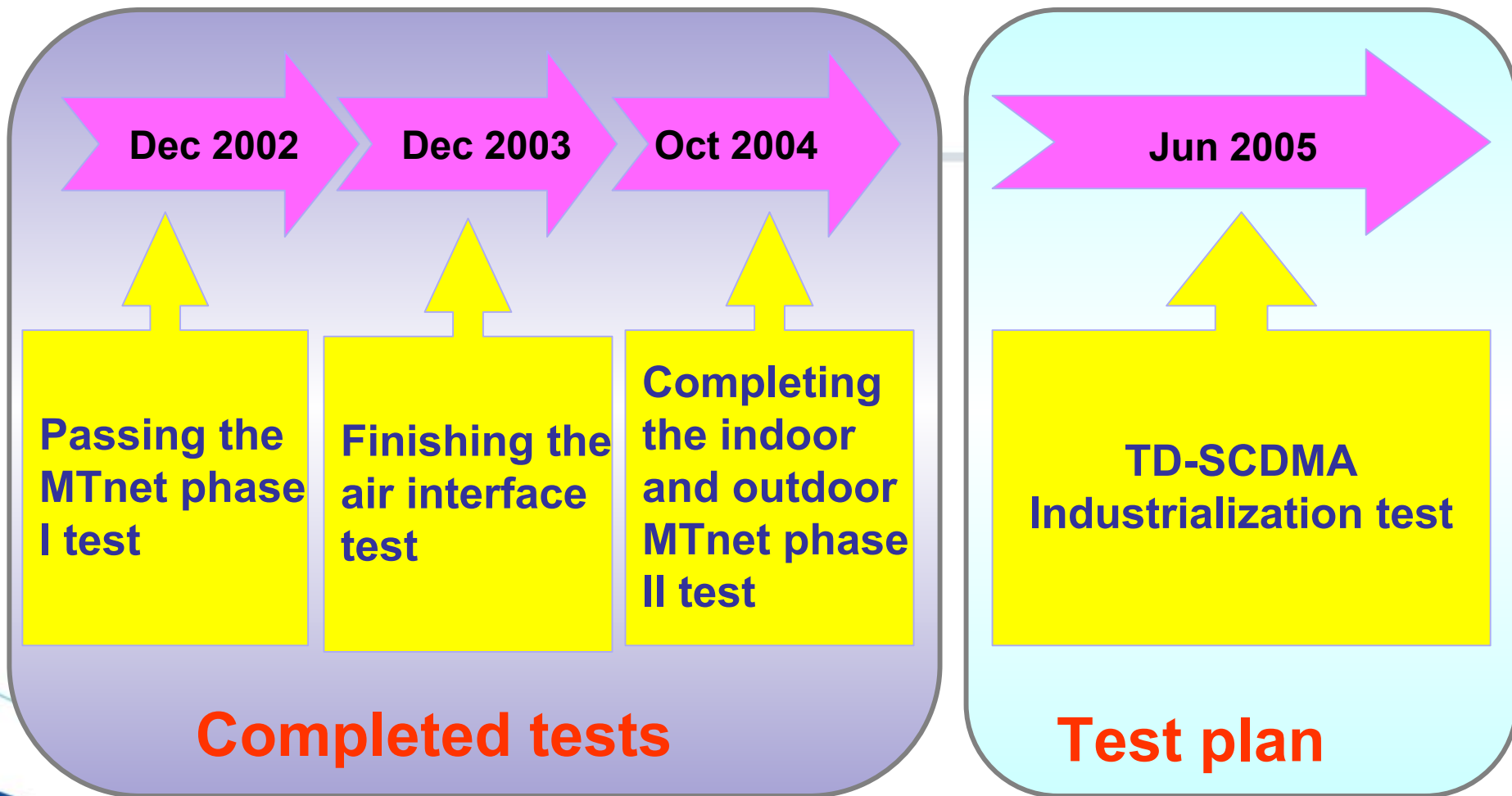

2006

Mass deployment

Commercialization

Pre-commercialization

Industrialization

2005



Thank you!