

5. 3GPP LTE

Brian (Bong Youl) Cho

brian.cho@intel.com

Contents

- Technology Evolution for 4G
- 3GPP HSPA Evolution
- 3GPP LTE Requirements
- 3GPP LTE Network Architecture
- 3GPP LTE PHY Feature Overview
- 3GPP LTE PHY Specifications
- 3GPP SAE

Technology Evolution for 4G

IMT-2000 / **IMT-Advanced** Capabilities*

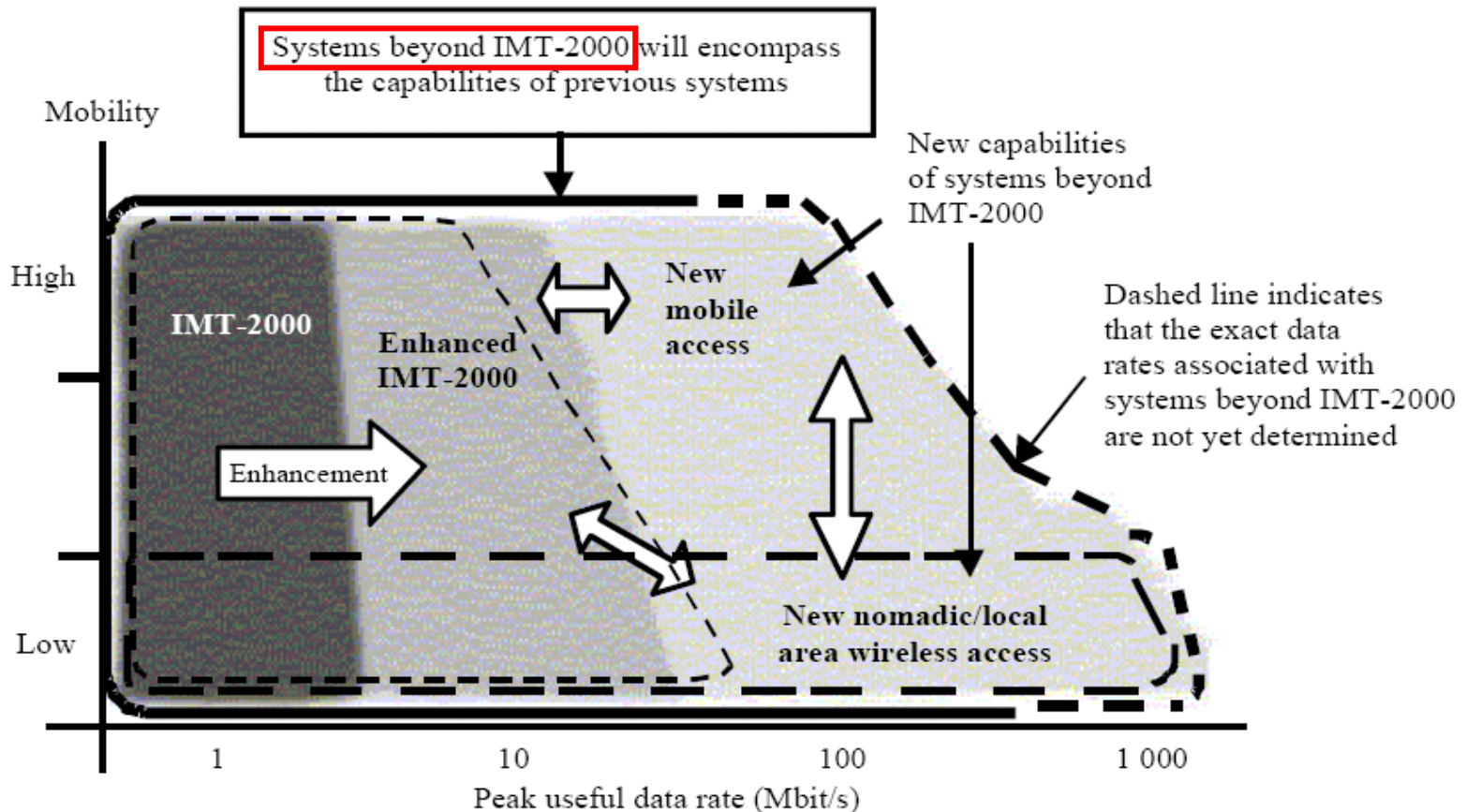

- **IMT-Advanced**

- Target Data rates up to 100Mbps for high mobility
- Target Data rates up to 1Gbps for low mobility
- The data rate targets are subject to further research and investigation

* ITU-R, "ITU-R RECOMMENDATION ITU-R M.1645: Framework and overall objectives of the future development of IMT-2000 and systems beyond IMT-2000", ITU-R, 2003

ITU-R

- ITU Radiocommunication Sector - Study Groups

Structure

- ▶ Study Group 1 (SG 1) - Spectrum management
- ▶ Study Group 3 (SG 3) - Radiowave propagation
- ▶ Study Group 4 (SG 4) - Satellite services
- ▶ Study Group 5 (SG 5) - Terrestrial Services
- ▶ Study Group 6 (SG 6) - Broadcasting service
- ▶ Study Group 7 (SG 7) - Science services
- ▶ Coordination Committee for Vocabulary (CCV)
- ▶ Conference Preparatory Meeting (CPM)
- ▶ Special Committee (SC)

- ITU Radiocommunication Sector - Study Group #5

Structure

Proposed structure

- ▶ Working Party 5A (WP 5A) - Land mobile service excluding IMT; amateur and amateur-satellite service
- ▶ Working Party 5B (WP 5B) - Maritime mobile service including Global Maritime Distress and Safety System (GMDSS); aeronautical mobile service and radiodetermination service
- ▶ Working Party 5C (WP 5C) - Fixed wireless systems; HF systems in the Fixed and Land Mobile Services
- ▶ Working Party 5D (WP 5D) - IMT Systems

IMT-Advanced Schedule*

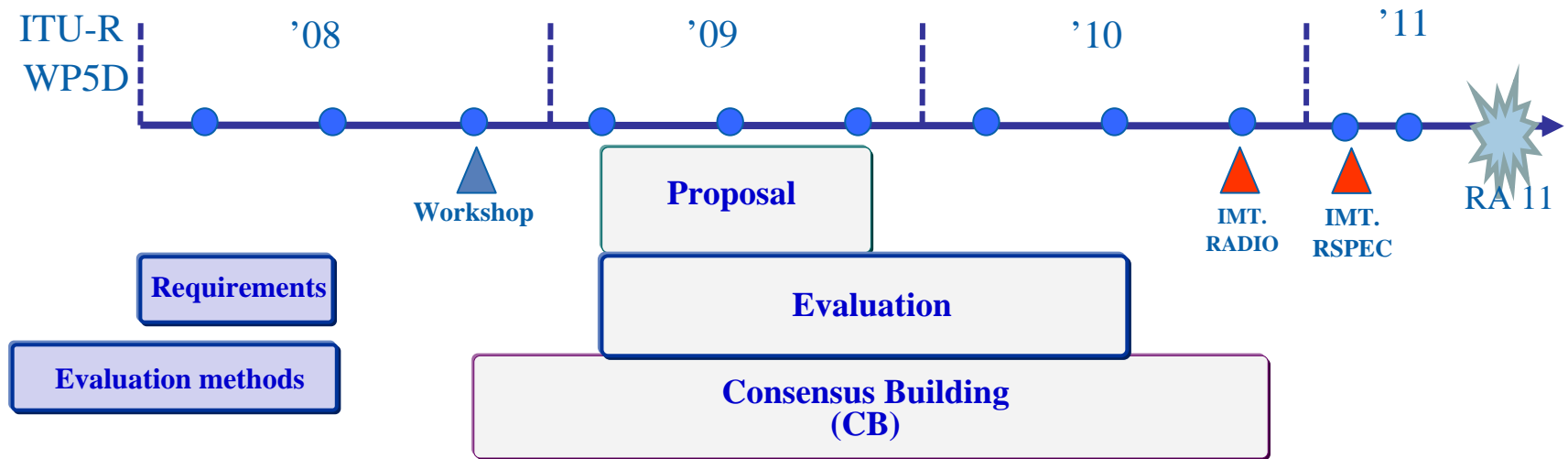

IMT.RADIO : IMT-Adv. Framework document

IMT.RSPEC : IMT-Adv. Core Specification

- Technology submission by the 6th WP5D meeting (by the end of 2009)
- Technology evaluation by the 8th WP5D meeting (by the middle of 2010) including the revision of the proposed technologies
- The release of the 1st version of IMT-Advanced Recommendations by the 10th WP5D meeting (the early 2011) but to be approved at RA-11.

4G Technology Evolution Path

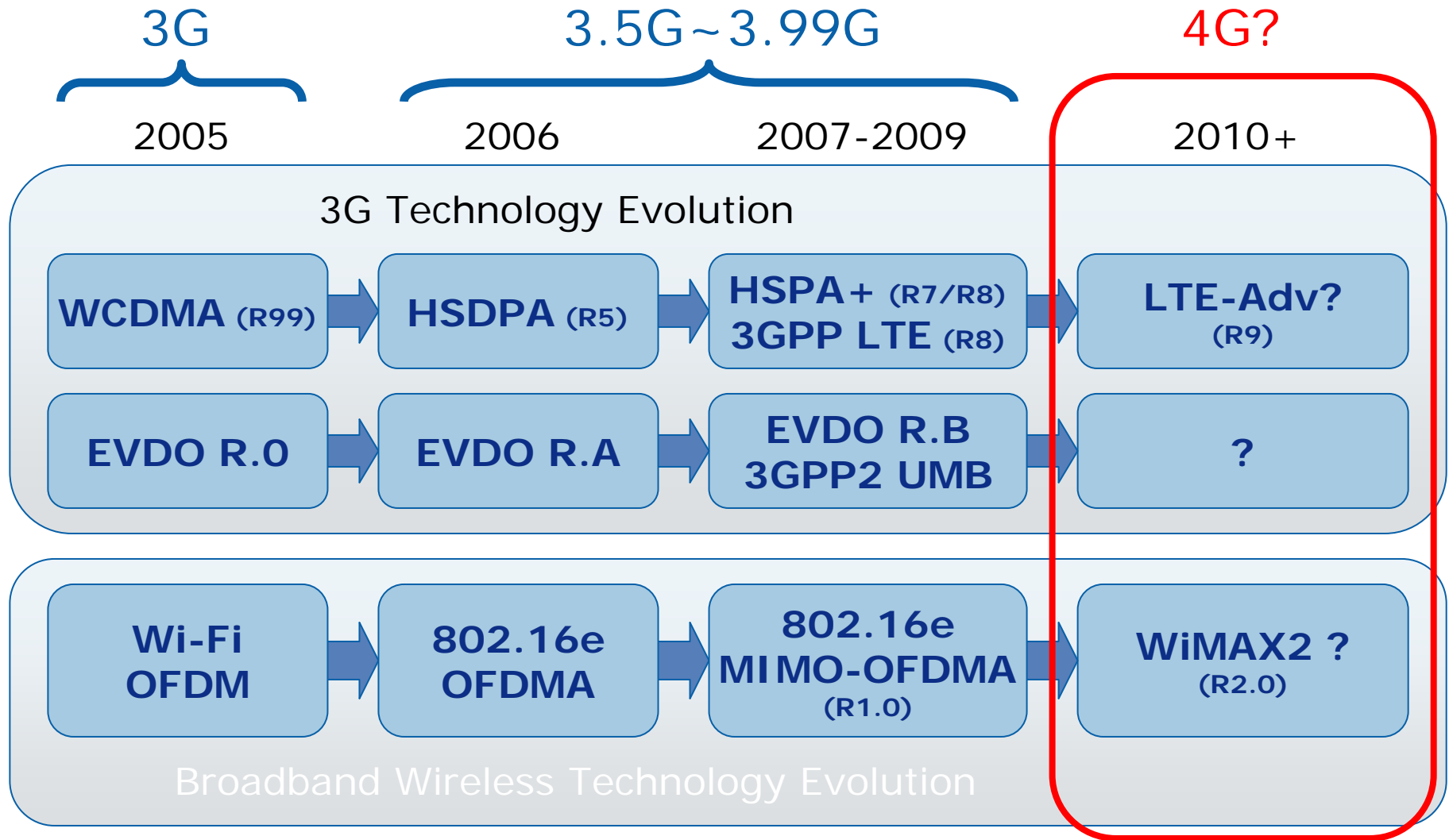

(General) Technology Evolution

WiMAX/LTE/UMB
have

Tolerance to Multipath and Self-Interference
Scalable Channel Bandwidth
Orthogonal Uplink Multiple Access
Support for Spectrally-Efficient TDD
Frequency-Selective Scheduling
Fractional Frequency Reuse
Fine Quality of Service (QoS)
Advanced Antenna Technology



WiMAX/HSDPA/
EVDO/LTE/UMB
have

AMC
H-ARQ
Fast Scheduling
Bandwidth Efficient Handoff



Old 3G Standards

Why Ultra High Speed System (e.g. 4G)?

The screenshot shows a Microsoft Internet Explorer browser window displaying a news article from itnews24.com. The article title is "ETRI, 세계 최초 4세대(G) 통신시스템 개발" (ETRI, World's First 4th Generation (G) Communication System Development). The sub-headline reads "CD 1장 1.4초만에 다운로드...외국과 1년 이상 기술 격차 벌려" (Download 1 CD in 1.4 seconds... widening the technology gap with foreign countries by more than a year). The author is listed as 강희종기자 hjkang@inews24.com. A red box highlights a key claim: "우리나라가 세계에서 처음으로 3.6Gbps 전송 속도를 구현하는 4세대(4G) 이동통신 시스템을 개발했다. 이는 650MB의 CD 1장을 단 1.4초만에 내려받을 수 있는 속도다." (Our country has developed the 4th generation (4G) mobile communication system, which is the first in the world to implement a transmission speed of 3.6 Gbps. This is a speed that can download 1 CD of 650 MB in just 1.4 seconds.) The article text continues to describe the system's capabilities and the company's progress.

Simple Calculation!

$$650 \text{ MB} = 650 \times 8 \text{ Mbits}$$
$$(650 \times 8) \text{ Mbits} / 3.6 \text{ Gbps} = 1.4 \text{ sec}$$

But... not a realistic usage model.

Why Ultra High Speed System (e.g. 4G)?







- 기지국 감가상각비용 
- 기지국 시설 감가상각비용 
- 전기료 
- 임대료 
- 전용선로 임차비 
- 유지보수 인건비 

그림 1.1 무선데이터 원가의 주요 요소와 시간에 따른 변동 예상



그림 1.2 : 기지국의 total throughput 에 따른 과금 근거

* 이상근, 조봉열, 여운영, "쉽게 설명한 3G/4G 이동통신시스템", 홍릉과학출판사, 2008년

3GPP HSPA Evolution

3GPP Standards Evolution

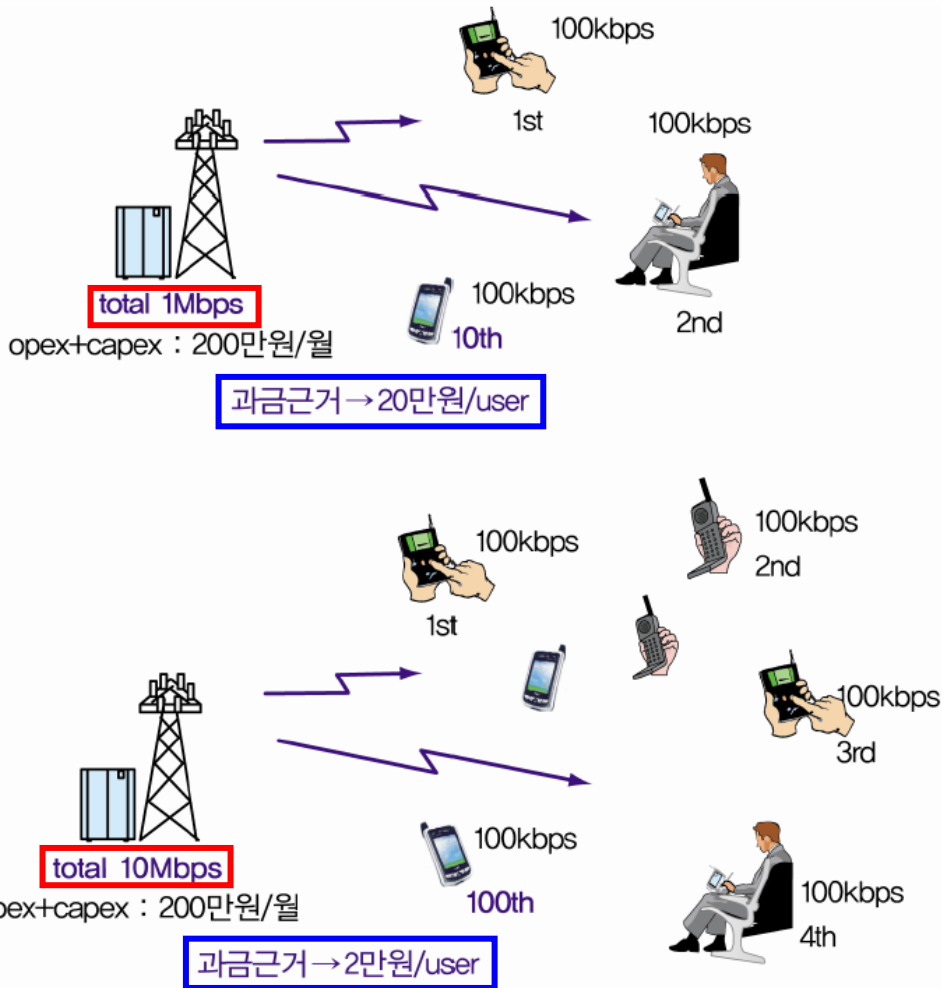
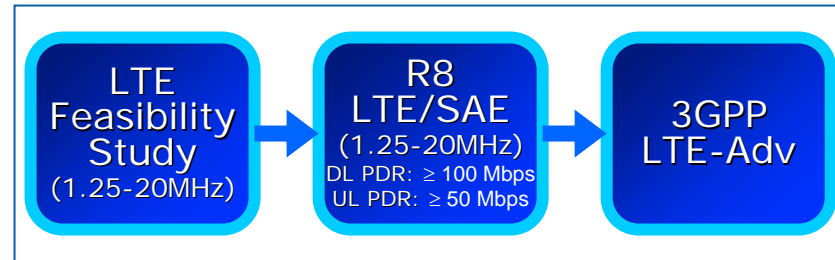
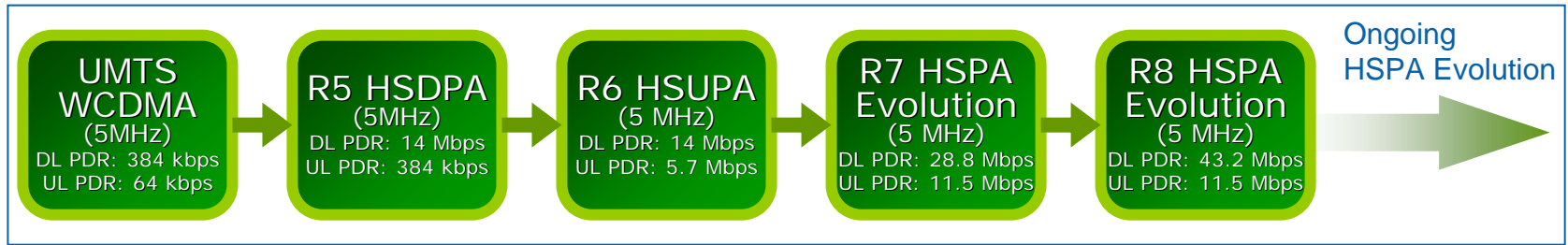
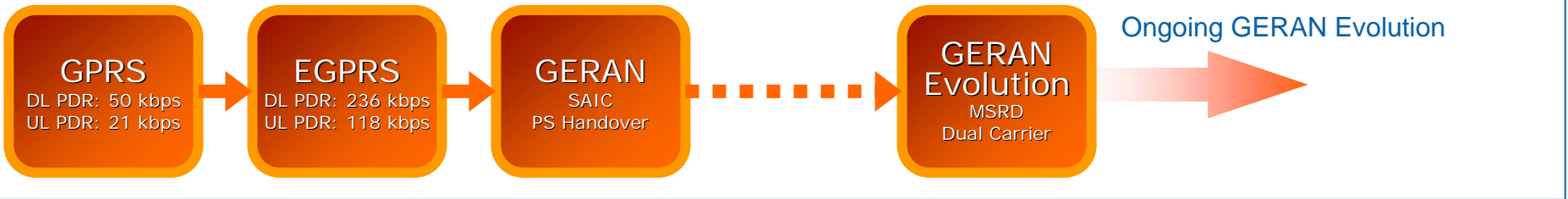

1999 2000 2001 2002 2003 2004 2005 2006 2007 2008 2009+

HSPA+

- Peak Data Rate of HSPA+ (with 5MHz BW)

	HSPA (R6)	HSPA+ (R7)	HSPA+ (R8)
DL	14.4 Mbps	28.8 Mbps ⁽¹⁾	43.2 Mbps ⁽³⁾
UL	5.76 Mbps	11.52 Mbps ⁽²⁾	11.52 Mbps

(1) MIMO SM doubles the peak data rate

(2) 16QAM doubles the peak data rate

(3) 64QAM can deliver (6/4) times more bits than 16QAM

3GPP LTE Requirements

3GPP Specifications

- LTE Study Phase (Release 7)
 - TR 25.813, E-UTRA and E-UTRAN: Radio interface protocol aspects
 - TR 25.814, Physical layer aspects for E-UTRA
 - TR 25.912, Feasibility study for E-UTRA and E-UTRAN
 - TR 25.913, Requirements for E-UTRA and E-UTRAN
- LTE Specifications (Release 8)
 - TS 36.101, E-UTRA: UE radio transmission and reception
 - TS 36.104, E-UTRA: BS radio transmission and reception
 - TS 36.201, LTE Physical Layer - General Description
 - TS 36.211, Physical channels and modulation
 - TS 36.212, Multiplexing and channel coding
 - TS 36.213, Physical layer procedures
 - TS 36.214, Physical layer – Measurements
 - TS 36.300, E-UTRA and E-UTRAN: Overall description; Stage 2
 - TR 36.803, E-UTRA: UE radio transmission and reception
 - TR 36.804, E-UTRA: BS radio transmission and reception
 - TR 36.938, Improved network controlled mobility between LTE and 3GPP2/mobile WiMAX radio technologies
 - TR 36.956, Evolved Universal Terrestrial Radio Access (E-UTRA); Repeater planning guidelines and system analysis
- SAE Study Phase and Specifications (Release 8)
 - TS 22.278, Service requirements for the Evolved Packet System (EPS)
 - TS 23.401, GPRS enhancements for E-UTRAN access
 - TS 23.402, Architecture enhancements for non-3GPP accesses

3GPP LTE

- LTE focus is on:
 - enhancement of the Universal Terrestrial Radio Access (UTRA)
 - optimisation of the UTRAN architecture
- With HSPA (downlink and uplink), UTRA will remain highly competitive for several years
- LTE project aims to ensure the continued competitiveness of the 3GPP technologies for the future
- Motivations
 - Need for PS optimized system
 - Evolve UMTS towards packet only system
 - Need for higher data rates
 - Can be achieved with HSDPA/HSUPA
 - and/or new air interface defined by 3GPP LTE
 - Need for high quality of services
 - Use of licensed frequencies to guarantee quality of services
 - Always-on experience (reduce control plane latency significantly)
 - Reduce round trip delay
 - Need for cheaper infrastructure
 - Simplify architecture, reduce number of network elements
 - Most data users are less mobile

LTE High Level Requirements

- Reduced cost per bit
- Increased service provisioning – more services at lower cost with better user experience
- Flexibility of use of existing and new frequency bands
- Simplified architecture, Open interfaces
- Allow for reasonable terminal power consumption

Detailed Requirements*

- Peak data rate
 - Instantaneous downlink peak data rate of 100 Mb/s within a 20 MHz downlink spectrum allocation (5 bps/Hz)
 - Instantaneous uplink peak data rate of 50 Mb/s (2.5 bps/Hz) within a 20MHz uplink spectrum allocation)
- Control-plane latency
 - Transition time of less than 100 ms from a camped state, such as Release 6 Idle Mode, to an active state such as Release 6 CELL_DCH
 - Transition time of less than 50 ms between a dormant state such as Release 6 CELL_PCH and an active state such as Release 6 CELL_DCH
- Control-plane capacity
 - At least 200 users per cell should be supported in the active state for spectrum allocations up to 5 MHz
- User-plane latency
 - Less than 5 ms in unload condition (ie single user with single data stream) for small IP packet

* 3GPP TR 25.913, Technical Specification Group RAN: Requirements for Evolved UTRA (E-UTRA) and Evolved UTRAN (E-UTRAN), Release 7, Version 7.3.0, March 2006.

Detailed Requirements

- User throughput
 - Downlink: average user throughput per MHz, 3 to 4 times Release 6 HSDPA
 - Uplink: average user throughput per MHz, 2 to 3 times Release 6 Enhanced Uplink
- Spectrum efficiency
 - Downlink: In a loaded network, target for spectrum efficiency (bits/sec/Hz/site), 3 to 4 times Release 6 HSDPA)
 - Uplink: In a loaded network, target for spectrum efficiency (bits/sec/Hz/site), 2 to 3 times Release 6 Enhanced Uplink
- Mobility
 - E-UTRAN should be optimized for low mobile speed from 0 to 15 km/h
 - Higher mobile speed between 15 and 120 km/h should be supported with high performance
 - Mobility across the cellular network shall be maintained at speeds from 120 km/h to 350 km/h (or even up to 500 km/h depending on the frequency band)
- Coverage
 - Throughput, spectrum efficiency and mobility targets above should be met for 5 km cells, and with a slight degradation for 30 km cells. Cells range up to 100 km should not be precluded.

Detailed Requirements

- Spectrum flexibility
 - E-UTRA shall operate in spectrum allocations of different sizes, including 1.25 MHz, 2.5 MHz, 5 MHz, 10 MHz, 15 MHz and 20 MHz in both the uplink and downlink. Operation in paired and unpaired spectrum shall be supported
- Co-existence and Inter-working with 3GPP RAT (UTRAN, GERAN)
- Architecture and migration
 - Single E-UTRAN architecture
 - The E-UTRAN architecture shall be packet based, although provision should be made to support systems supporting real-time and conversational class traffic
 - E-UTRAN architecture shall support an end-to-end QoS
 - Backhaul communication protocols should be optimized
- Radio Resource Management requirements
 - Enhanced support for end to end QoS
 - Support of load sharing and policy management across different Radio Access Technologies
- Complexity
 - Minimize the number of options
 - No redundant mandatory features

LTE System Performance

- Peak Data Rate

Case		Peak Date Rate (Mbps)	
Downlink (64QAM, 20MHz)	2x2 MIMO	172.8	← baseline
	4x2 MIMO	326.4	
Uplink (20MHz)	16QAM	57.6	
	64QAM	86.4	← baseline

- VoIP Capacity

Deployment Scenario	Average VoIP Capacity (users/sector)	
	DL	UL
Case1	317	241
Case2	293	-
Case3	289	123

* 정재훈 (LGE), "Basics and Core Technologies of 3GPP LTE Physical Layer", 제3회 차세대 이동통신 기술 단기강좌, Aug. 2007

LTE System Performance – cont'd

- Downlink Spectral Efficiency

		Spectrum Efficiency		Mean User Throughput		Cell-Edge User Throughput	
		[bps/Hz/cell]	x UTRA	[bps/Hz/user]	x UTRA	[bps/Hz/user]	x UTRA
Case 1 (ISD 500m, UE speed 3km/h)	UTRA baseline 1x2	0,53	x1,0	0,05	x1,0	0,02	x1,0
	E-UTRA 2x2 SU-MIMO	1,69	x3,2	0,17	x3,2	0,05	x2,7
	E-UTRA 4x2 SU-MIMO	1,87	x3,5	0,19	x3,5	0,06	x3,0
	E-UTRA 4x4 SU-MIMO	2,67	x5,0	0,27	x5,0	0,08	x4,4
Case 3 (ISD 1732m, UE speed 3km/h)	UTRA baseline 1x2	0,52	x1,0	0,05	x1,0	0,02	x1,0
	E-UTRA 2x2 SU-MIMO	1,56	x3,0	0,16	x3,0	0,04	x2,3
	E-UTRA 4x2 SU-MIMO	1,85	x3,6	0,19	x3,6	0,05	x2,8
	E-UTRA 4x4 SU-MIMO	2,41	x4,6	0,24	x4,6	0,08	x4,8

- Uplink Spectral Efficiency

		Spectrum Efficiency		Mean User Throughput		Cell-Edge User Throughput	
		[bps/Hz/cell]	x UTRA	[bps/Hz/user]	x UTRA	[bps/Hz/user]	x UTRA
Case 1 (ISD 500m, UE speed 3km/h)	UTRA baseline	0.332	x1.0	0.033	x1.0	0.009	x1.0
	E-UTRA 1x2	0.735	x2.2	0.073	x2.2	0.024	x2.5
	E-UTRA 1x4	1.103	x3.3	0.110	x3.3	0.052	x5.5
	E-UTRA 2x2 SU-MIMO	0.776	x2.3	0.078	x2.3	0.010	x1.1
Case 3 (ISD 1732m, UE speed 3km/h)	UTRA baseline	0.316	x1.0	0.032	x1.0	0.0023	x1.0
	E-UTRA 1x2	0.681	x2.2	0.068	x2.2	0.0044	x2.0
	E-UTRA 1x4	1.038	x3.3	0.104	x3.3	0.0094	x4.2

3GPP LTE Network Architecture

E-UTRAN Architecture*

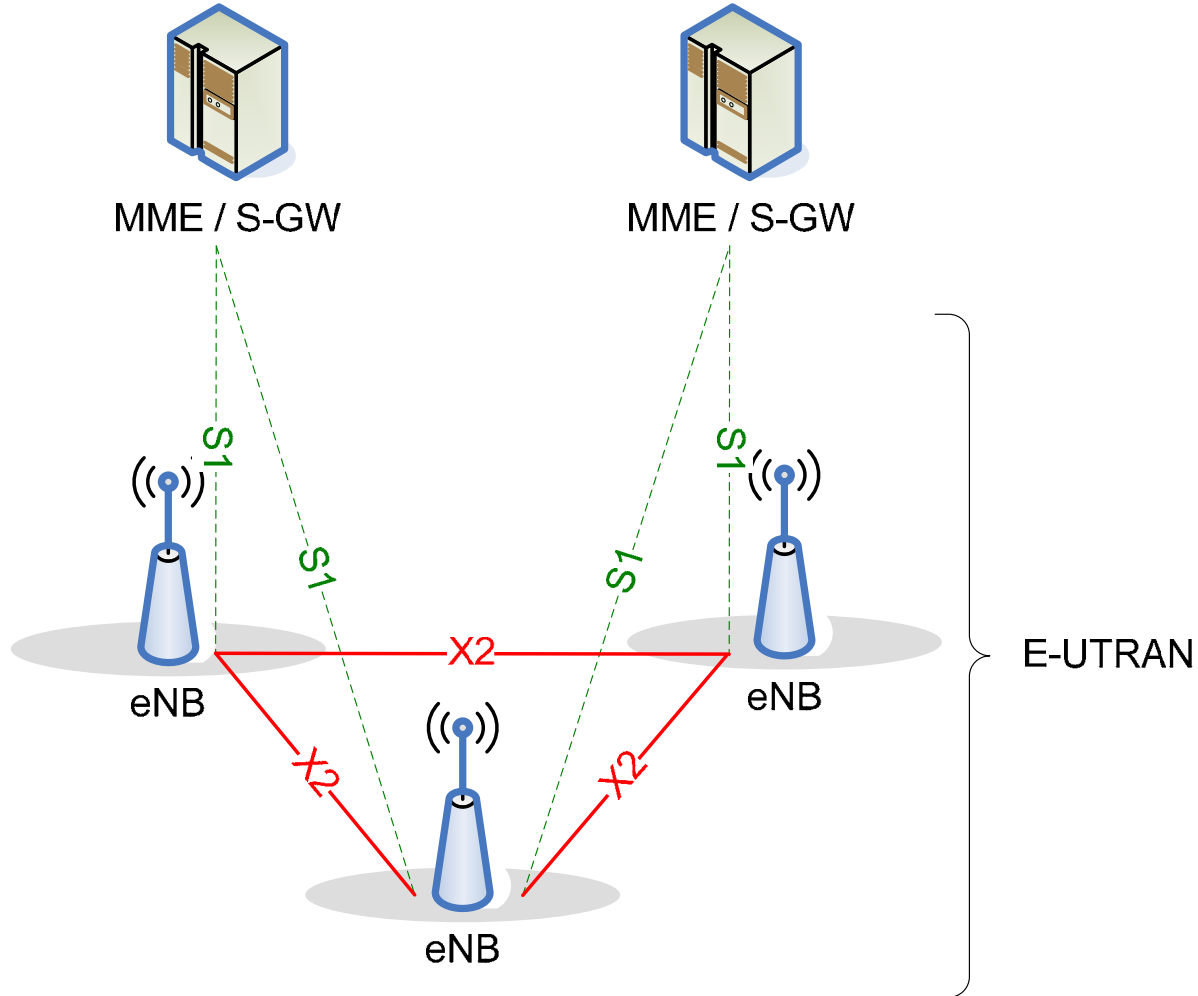

* 3GPP TS 36.300, E-UTRA and E-UTRAN; Overall description; Stage 2, Release 8, V8.3.0, Jan. 2008.

Functional Split b/w E-UTRAN and EPC*

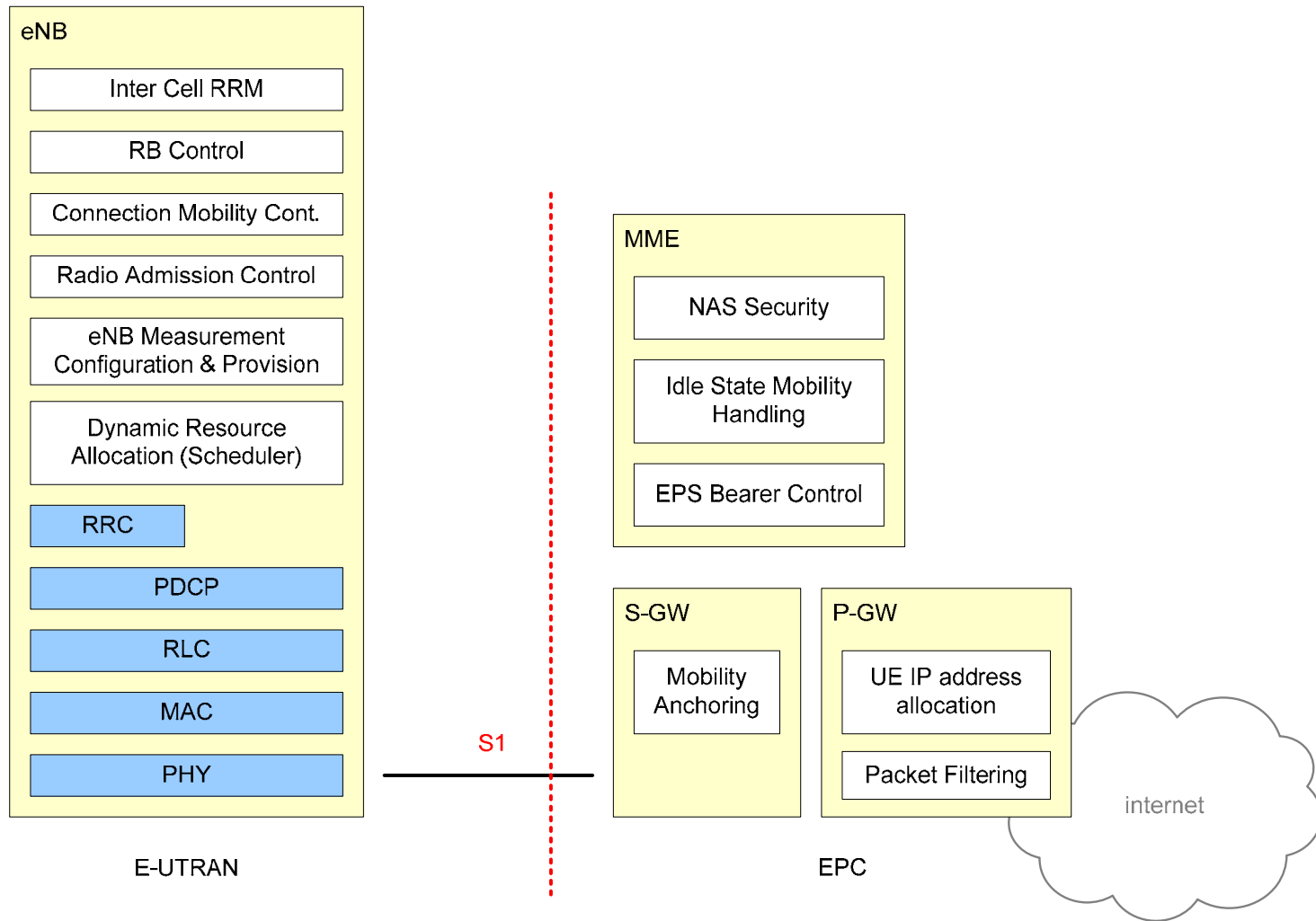

* 3GPP TS 36.300, E-UTRA and E-UTRAN; Overall description; Stage 2, Release 8, V8.3.0, Jan. 2008.

3GPP LTE PHY Feature Overview

Shift of Key Technologies in LTE*

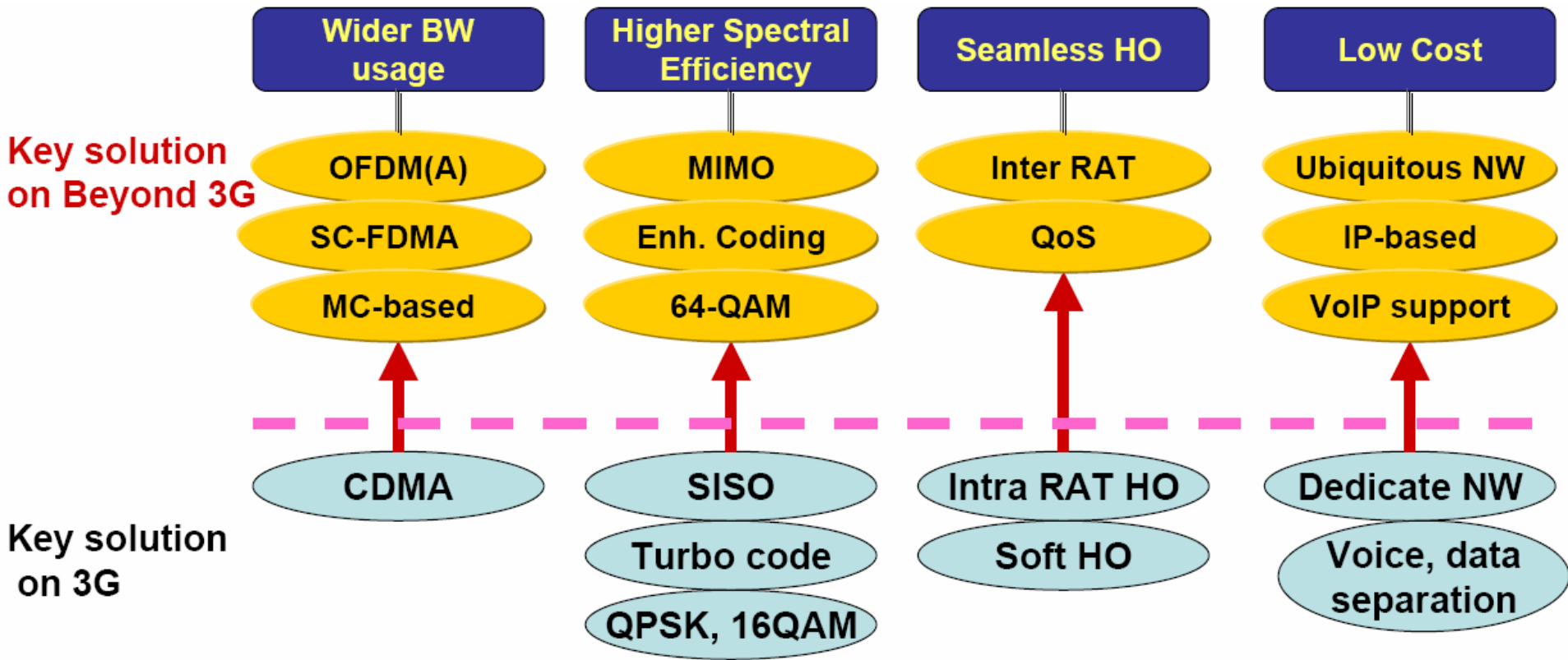

* 오민석 (LGE), "3GPP LTE", KRnet 2007, June 29 2007

LTE PHY Key Features

- Downlink: **OFDMA (Orthogonal Frequency Division Multiple Access)**
 - Less critical AMP efficiency in BS side
 - Concerns on high RX complexity in terminal side
- Uplink: **SC-FDMA (Single Carrier-FDMA)**
 - Less critical RX complexity in BS side
 - Critical AMP complexity in terminal side (Cost, power Consumption, UL coverage)
- Support FDD (frame type 1*) & TDD (frame type 2 for TD-SCDMA)
- User data rates
 - DL (baseline): 172.8 Mbps @ 20 MHz BW w/ 2x2 SU-MIMO
 - UL (baseline): 86.4 Mbps @ 20 MHz BW w/ non-MIMO or 1x2 MU-MIMO
- Radio frame: 10 ms (= 20 slots)
Sub-frame: 1 ms (= 2 slots)
Slot: 0.5 ms
- TTI: 1 ms
- HARQ retransmission time: 7 or 8ms
- Modulation
 - DL/UL data channel = QPSK/16QAM/64QAM

LTE PHY Key Features – cont'd

- MIMO SM (Spatial Multiplexing), Beamforming, Antenna Diversity
Min requirement: 2 eNB antennas & 2 UE rx antennas
 - DL: Single-User MIMO up to 4x4 supportable
 - UL: 1x2 MU-MIMO, Optional 2x2 SU-MIMO
- Resource block
 - 12 subcarriers with subcarrier BW of 15kHz
 - 24 subcarriers with subcarrier BW of 7.5kHz (only for MBMS)
- Subcarrier operation
 - Frequency selective (partial band)
 - Frequency diversity by frequency hopping
- Frequency hopping
 - Intra-TTI: UL (once per 0.5ms slot), DL (once per 66us symbol)
 - Inter-TTI: across retransmissions
- Bearer services
 - Packet only – no circuit switched voice or data services are supported
 - Voice must use VoIP
- MBSFN
 - Multicast/Broadcast over a Single Frequency Network
 - To support a Multimedia Broadcast and Multicast System (MBMS)
 - Time-synchronized common waveform is transmitted from multiple cells for a given duration

DL/UL Data Channel Modulation

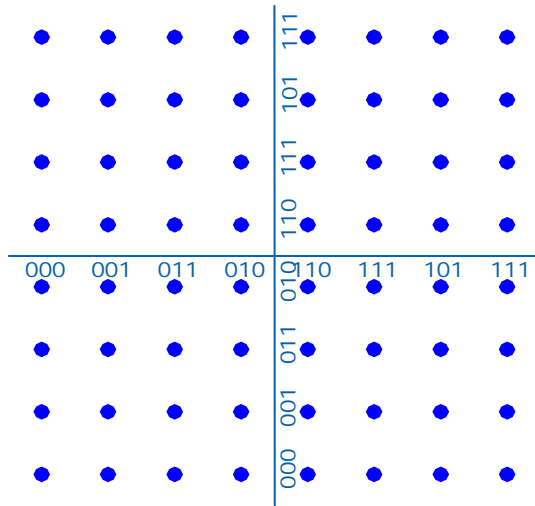

64-QAM

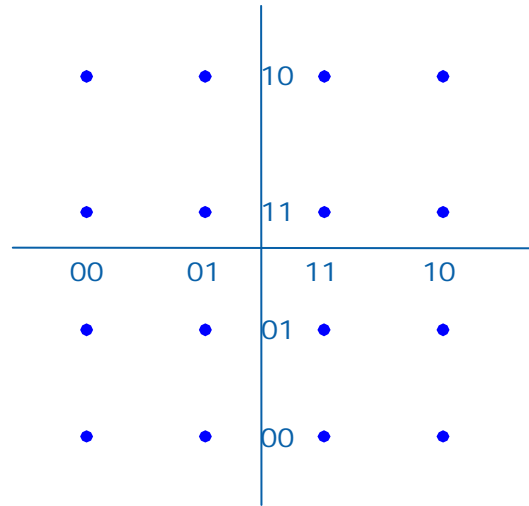

16-QAM

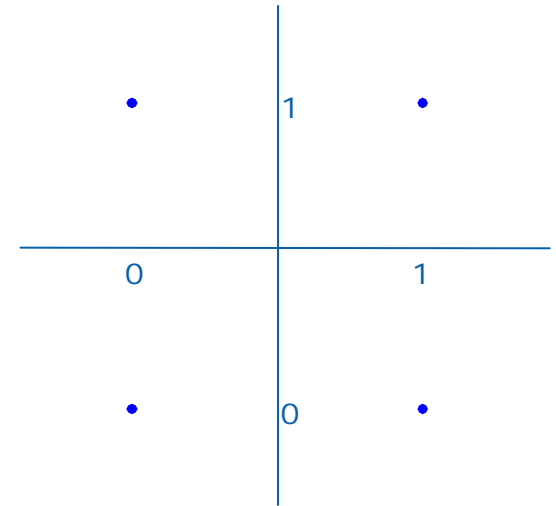

QPSK

E-UTRA Frequency Band*

Table 5.2-1 E-UTRA frequency bands

E-UTRA Band	Uplink (UL) eNode B receive UE transmit	Downlink (DL) eNode B transmit UE receive	UL-DL Band separation	Duplex Mode
	F_{UL_low} – F_{UL_high}	F_{DL_low} – F_{DL_high}	F_{DL_low} - F_{UL_high}	
1	1920 MHz – 1980 MHz	2110 MHz – 2170 MHz	130 MHz	FDD
2	1850 MHz – 1910 MHz	1930 MHz – 1990 MHz	20 MHz	FDD
3	1710 MHz – 1785 MHz	1805 MHz – 1880 MHz	20 MHz	FDD
4	1710 MHz – 1755 MHz	2110 MHz – 2155 MHz	355 MHz	FDD
5	824 MHz – 849 MHz	869 MHz – 894MHz	20 MHz	FDD
6	830 MHz – 840 MHz	875 MHz – 885 MHz	35 MHz	FDD
7	2500 MHz – 2570 MHz	2620 MHz – 2690 MHz	50 MHz	FDD
8	880 MHz – 915 MHz	925 MHz – 960 MHz	10 MHz	FDD
9	1749.9 MHz – 1784.9 MHz	1844.9 MHz – 1879.9 MHz	60 MHz	FDD
10	1710 MHz – 1770 MHz	2110 MHz – 2170 MHz	340 MHz	FDD
11	1427.9 MHz – 1452.9 MHz	1475.9 MHz – 1500.9 MHz	23 MHz	FDD
12	[TBD] – [TBD]	[TBD] – [TBD]	[TBD]	FDD
13	777 MHz – 787 MHz	746 MHz – 756 MHz	21	FDD
14	788 MHz – 798 MHz	758 MHz – 768 MHz	20	FDD
...				
33	1900 MHz – 1920 MHz	1900 MHz – 1920 MHz	N/A	TDD
34	2010 MHz – 2025 MHz	2010 MHz – 2025 MHz	N/A	TDD
35	1850 MHz – 1910 MHz	1850 MHz – 1910 MHz	N/A	TDD
36	1930 MHz – 1990 MHz	1930 MHz – 1990 MHz	N/A	TDD
37	1910 MHz – 1930 MHz	1910 MHz – 1930 MHz	N/A	TDD
38	2570 MHz – 2620 MHz	2570 MHz – 2620 MHz	N/A	TDD
39	1880 MHz - 1920 MHz	1880 MHz - 1920 MHz	N/A	TDD
40	2300 MHz - 2400 MHz	2300 MHz - 2400 MHz	N/A	TDD

E-UTRA Channel Bandwidth*

Table 5.4.2-1 Transmission bandwidth configuration N_{RB} in E-UTRA channel bandwidths

Channel bandwidth $BW_{Channel}$ [MHz]	1.4	3	5	10	15	20
N_{RB}	6	15	25	50	75	100

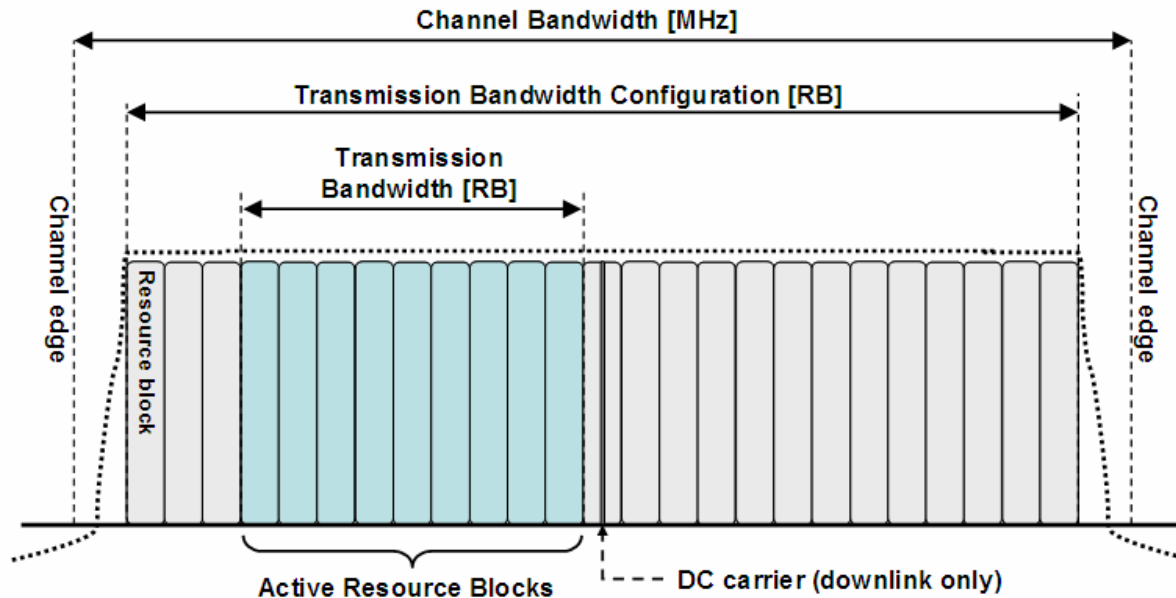

Figure 5.4-1 Definition of Channel Bandwidth and Transmission Bandwidth Configuration.

EARFCN*

- E-UTRA Absolute Radio Frequency Channel Number*
- N_{DL} is DL EARFCN and N_{UL} is UL EARFCN

$$F_{DL} = F_{DL_low} + 0.1(N_{DL} - N_{Offs-DL})$$

$$F_{UL} = F_{UL_low} + 0.1(N_{UL} - N_{Offs-UL})$$

Table 5.4.4-1 E-UTRA channel numbers

Band	Downlink			Uplink		
	F_{DL_low}	$N_{Offs-DL}$	Range of N_{DL}	F_{UL_low}	$N_{Offs-UL}$	Range of N_{UL}
1	2110	0	0 – 599	1920	13000	13000 – 13599
2	1930	600	600 – 1199	1850	13600	13600 – 14199
3	1805	1200	1200 – 1949	1710	14200	14200 – 14949
4	2110	1950	1950 – 2399	1710	14950	14950 – 15399
5	869	2400	2400 – 2649	824	15400	15400 – 15649
6	875	2650	2650 – 2749	830	15650	15650 – 15749
7	2620	2750	2750 – 3449	2500	15750	15750 – 16449
8	925	3450	3450 – 3799	880	16450	16450 – 16799
9	1844.9	3800	3800 – 4149	1749.9	16800	16800 – 17149
10	2110	4150	4150 – 4749	1710	17150	17150 – 17749
11	1475.9	4750	4750 – 4999	1427.9	17750	17750 – 17999
12						
13						
14						
...						
33	1900	26000	26000 – 26199	1900	26000	26000 – 26949
34	2010	26200	26200 – 26349	2010	26200	26200 – 26349
35	1850	26350	26350 – 26949	1850	26350	26320 – 26904
36	1930	26950	26950 – 27549	1930	26950	26950 – 27549
37	1910	27550	27550 – 27749	1910	27550	27550 – 27749
38	2570	27750	27750 – 28249	2570	27750	27750 – 28249
39	1880	28250	28250-28649	1880	28250	28250-28649
40	2300	28650	28650-29649	2300	28650	28650-29649

* UTRA Absolute Radio Frequency Channel Number (UARFCN)

OFDM

- Advantages
 - Easily adapt to severe channel conditions “without complex equalization”
 - Robust against narrow-band co-channel interference
 - Robust against ISI and fading caused by multipath propagation
 - High spectral efficiency
 - Efficient implementation using FFT
 - Low sensitivity to time synchronization errors
 - Low sensitivity to DC noise
 - Efficient in MIMO processing
 - Tuned sub-channel filters are not required (unlike conventional FDM)
 - Facilitates Single Frequency Networks, i.e. transmitter macrodiversity
- Disadvantages
 - Sensitive to Doppler shift & frequency synchronization problems
 - Inefficient transmitter power consumption, due to linear power amplifier requirement
 - Generic data rate loss and power loss due to CP (Cyclic Prefix)

CDMA vs. OFDM(A)

	CDMA	OFDM(A)
셀 간 (섹터 간) 간섭	있음	있음
셀 내 다중사용자 간 간섭	있음	없음
심볼 간 간섭	있음	없음
MIMO 프로세싱	비교적 높은 복잡도	비교적 낮은 복잡도

OFDM in Communication Systems

- WiBro (Mobile WiMAX)
- 3GPP LTE
- 3GPP2 UMB
- DAB, DVB-T, DVB-H
- T-DMB
- MediaFlo
- IEEE 802.11a WLAN
- xDSL
- PLC
- Etc...

OFDMA

- What is OFDMA?
 - OFDM Access
 - Orthogonal FDMA
- The advantages of OFDMA
 - Scheduling: TDMA + FDMA
 - BW Scalability
 - MS Power Concentration in Uplink
 - Frequency Diversity through “distributed subcarrier allocation”
 - Frequency Selective Scheduling Gain through “adjacent subcarrier allocation”
 - Flexible Frequency Reuse Factor to Reduce Interference
 - Etc...

SC-FDMA Transmitter

- SC-FDMA is a new hybrid modulation technique combining the low PAR single carrier methods of current systems with the frequency allocation flexibility and long symbol time of OFDM
- SC-FDMA is sometimes referred to as Discrete Fourier Transform Spread OFDM = DFT-SOOFDM

Signal at each subcarrier is linear combination of all M symbols

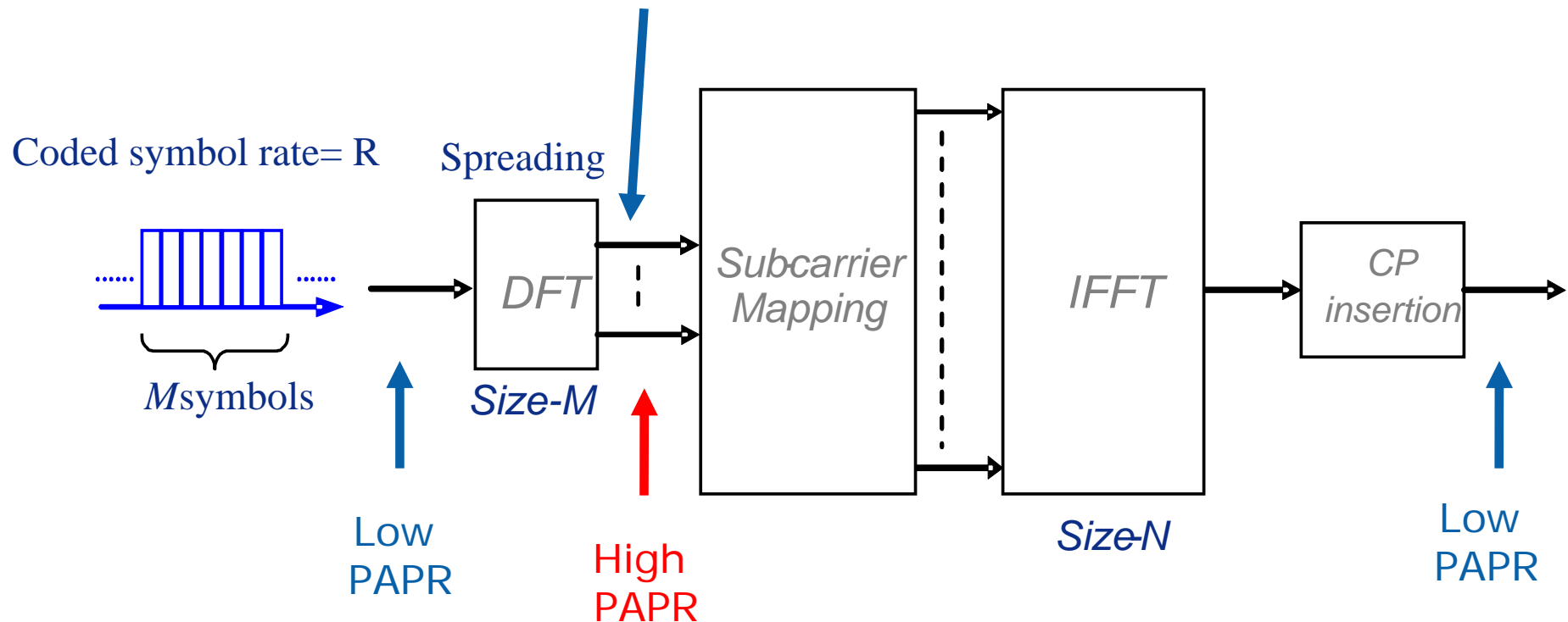

SC-FDMA Tx/Rx Chain

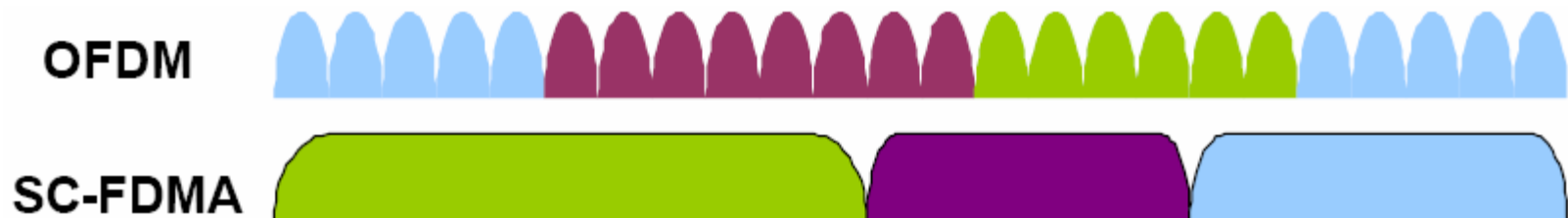
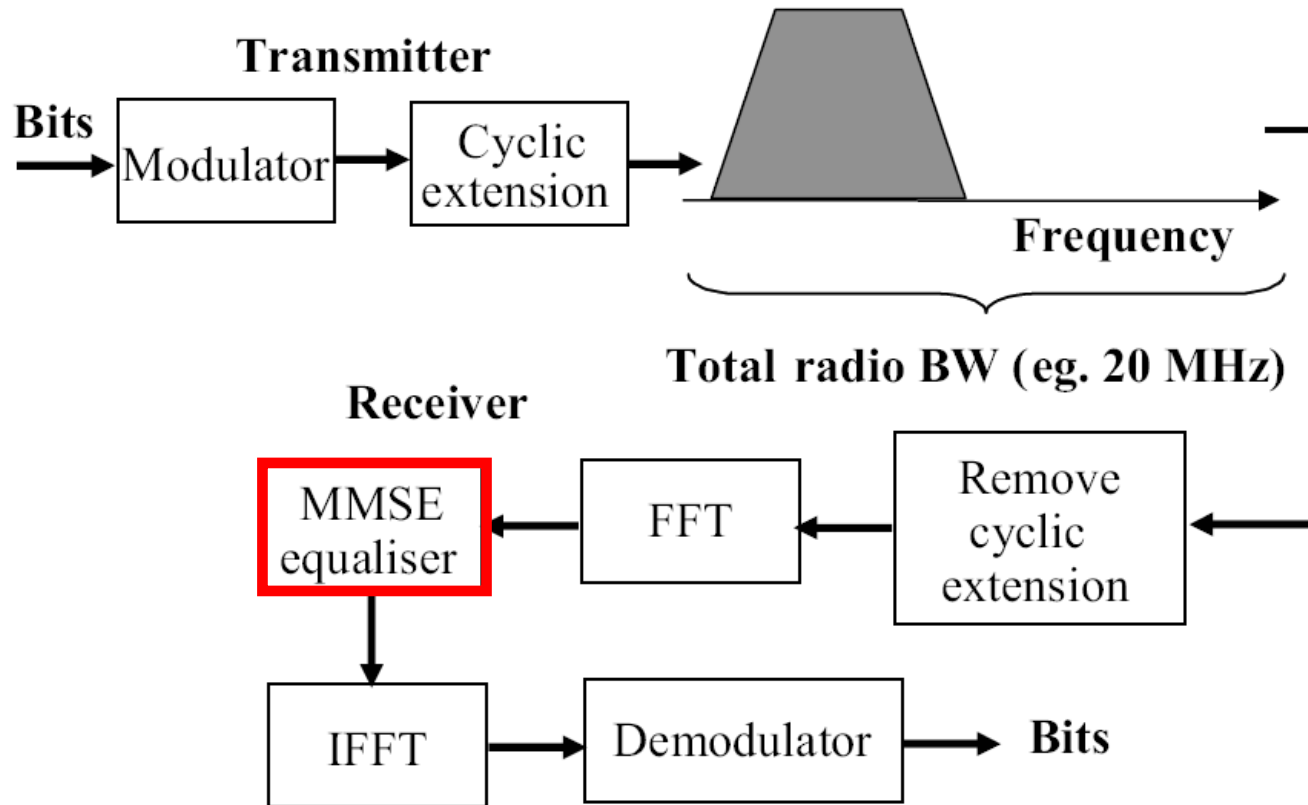

Detailed PHY Specifications

LTE Layer1 TS in 3GPP

- TS 36.201, LTE Physical Layer - General Description, Release 8, V8.1.0, Nov. 2007.
- TS 36.211, Physical channels and modulation, Release 8, V8.2.0, March 2008
- TS 36.212: Multiplexing and channel coding, Release 8, V8.2.0, March 2008
- TS 36.213: Physical layer procedures, Release 8, V8.2.0, March 2008
- TS 36.214: Physical layer – Measurements, Release 8, V8.2.0, March 2008

- TS 36.300: E-UTRA and E-UTRAN; Overall description; Stage 2, Release 8, V8.4.0, March 2008.

Layer1 Service to Higher Layer

- Error detection on the transport channel and indication to higher layers
- FEC encoding/decoding of the transport channel
- Hybrid ARQ soft-combining
- Rate matching of the coded transport channel to physical channels
- Mapping of the coded transport channel onto physical channels
- Power weighting of physical channels
- Modulation and demodulation of physical channels
- Frequency and time synchronisation
- Radio characteristics measurements and indication to higher layers
- Multiple Input Multiple Output (MIMO) antenna processing
- Transmit Diversity (TX diversity)
- Beamforming
- RF processing. (TS 36.100 series)

Physical Layer Specifications

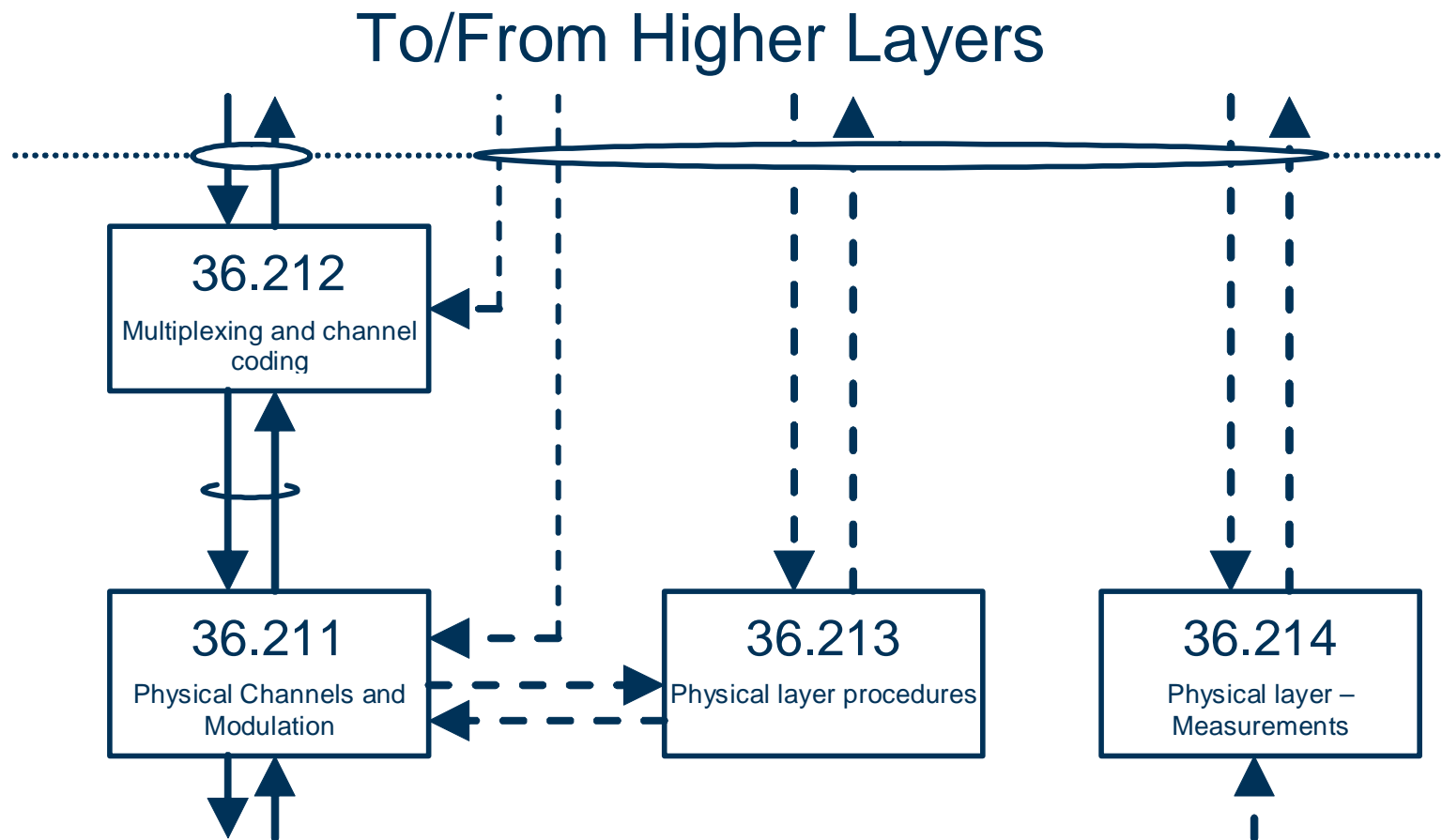

Frame Structure

- Generic frame structure

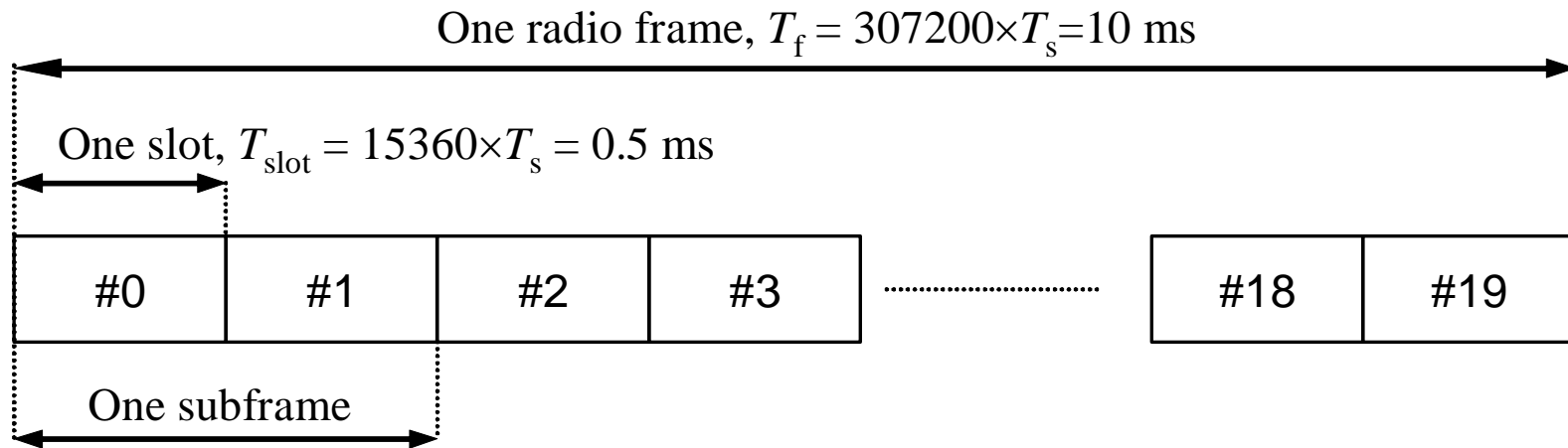

where, $T_s = 1/(15000 \times 2048)$ seconds \rightarrow "the smallest time unit in LTE"
 $T_f = 307200 \times T_s = 10$ ms

- There is alternative frame structure only applicable to TDD

Frame Structure – TDD

- For TD-SCDMA support

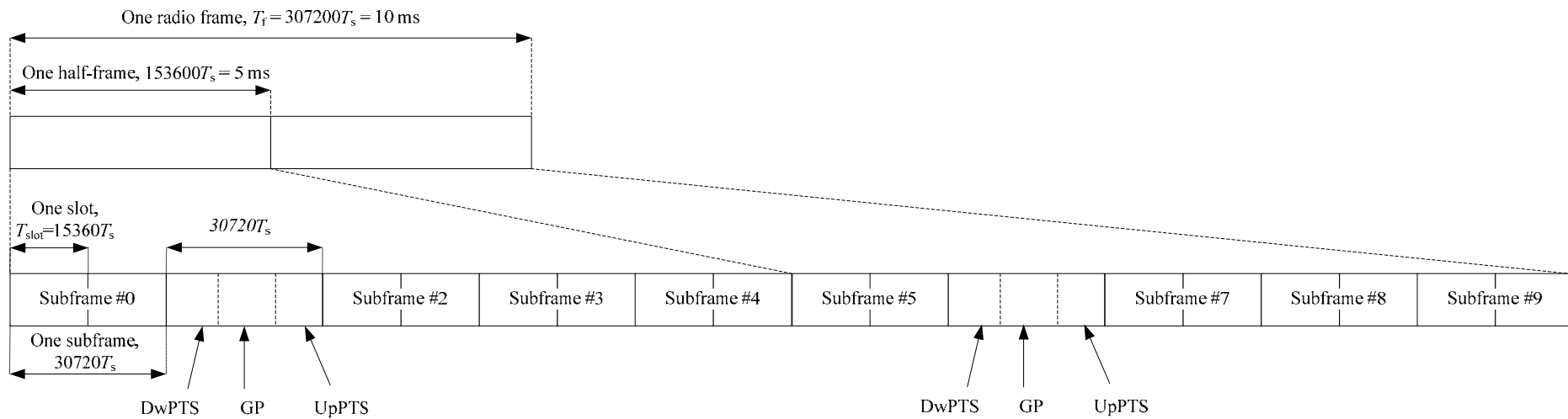

DL Physical Channels

- PDSCH (Downlink Shared Channel)
 - Carries DL-SCH and PCH
- PBCH (Broadcast Channel)
 - 4 subframes within a 40 ms interval
 - 40 ms timing is blindly detected
- PMCH
 - Carries MCH
- PCFICH (Control Format Indicator Channel)
 - Informs UE about the number of OFDM symbols used for PDCCHs transmission in every subframe
- PDCCH (Downlink Control Channel)
 - Informs UE about resource allocation of PCH and DL-SCH
 - HARQ information related to DL-SCH
 - UL scheduling grant
- PHICH
 - Carries HARQ ACK/NACKs in response to UL transmission

DL Physical Signals

- Reference Signals
 - Cell-specific RS, associated with non-MBSFN transmission
 - MBSFN RS, associated with MBSFN transmission
 - UE-specific RS
- Synchronization Signals
 - Carries frequency and symbol timing synchronization

DL Slot Structure

- N_{RB}^{DL} : Downlink bandwidth configuration, expressed in units of N_{sc}^{RB}
- N_{sc}^{RB} : Resource block size in the frequency domain, expressed as a number of subcarriers
- N_{symb}^{DL} : Number of OFDM symbols in an downlink slot

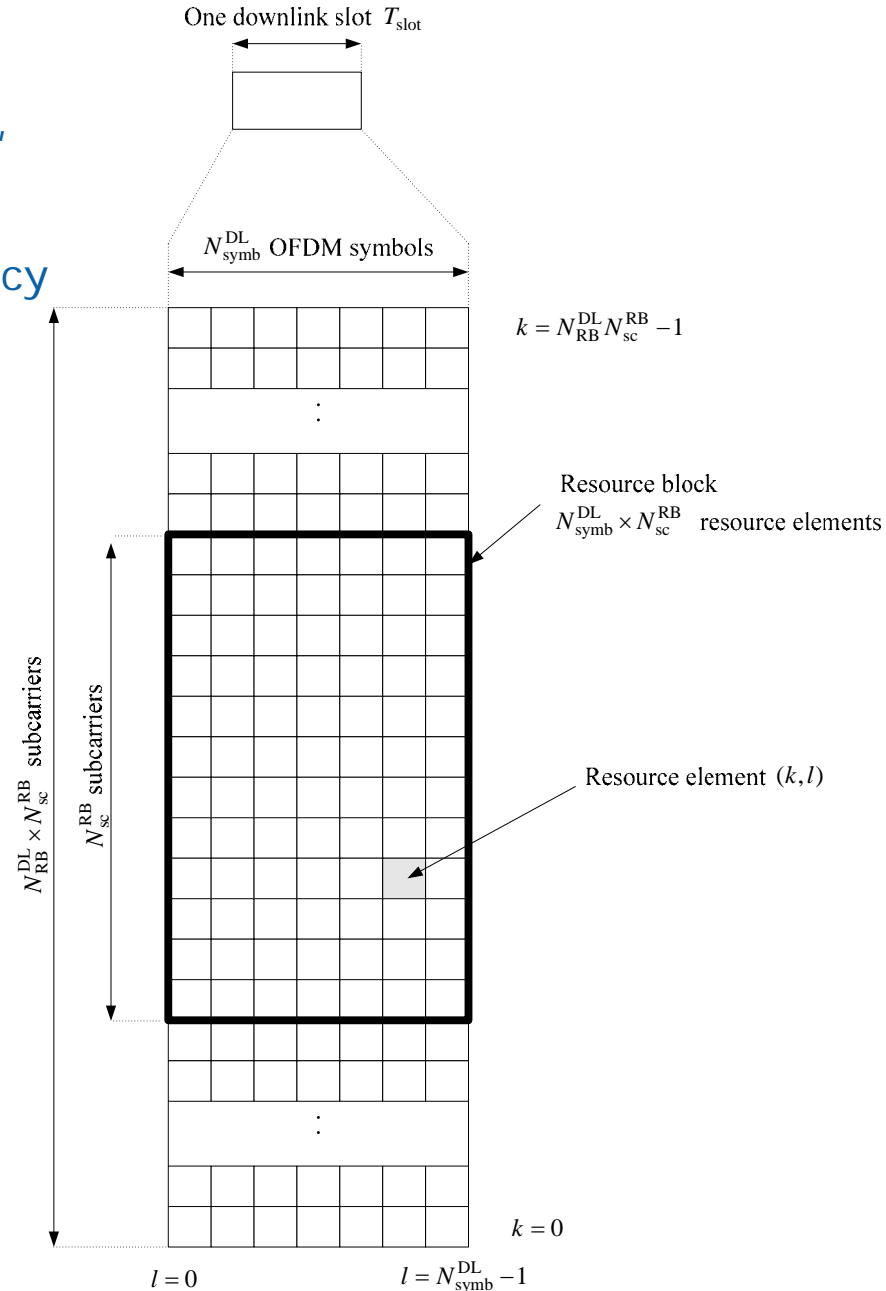

Definitions

- Resource Grid

- Defined as $N_{RB}^{DL} N_{sc}^{RB}$ subcarriers in frequency domain and N_{symb}^{DL} OFDM symbols in time domain
- The quantity N_{RB}^{DL} depends on the UL transmission BW configured in the cell and shall fulfill $6 \leq N_{RB}^{DL} \leq 110$
- The set of allowed values for N_{RB}^{DL} is given by TS 36.101, TS 36.104

- Resource Block

- Defined as N_{sc}^{RB} "consecutive" subcarriers in frequency domain and N_{symb}^{DL} "consecutive" OFDM symbols in time domain
- Corresponding to one slot in the time domain and 180 kHz in the frequency domain

Table 6.2.3-1: Physical resource blocks parameters.

Configuration		N_{sc}^{RB}	N_{symb}^{DL}
Normal cyclic prefix	$\Delta f = 15$ kHz	12	7
	$\Delta f = 7.5$ kHz		6
Extended cyclic prefix	$\Delta f = 7.5$ kHz	24	3

- Resource Element

- Uniquely defined by the index pair (k, l) in a slot where $k = 0, \dots, N_{RB}^{DL} N_{sc}^{RB} - 1$ and $l = 0, \dots, N_{symb}^{DL} - 1$ are the indices in the frequency and time domain, respectively

DL Physical Channel Processing

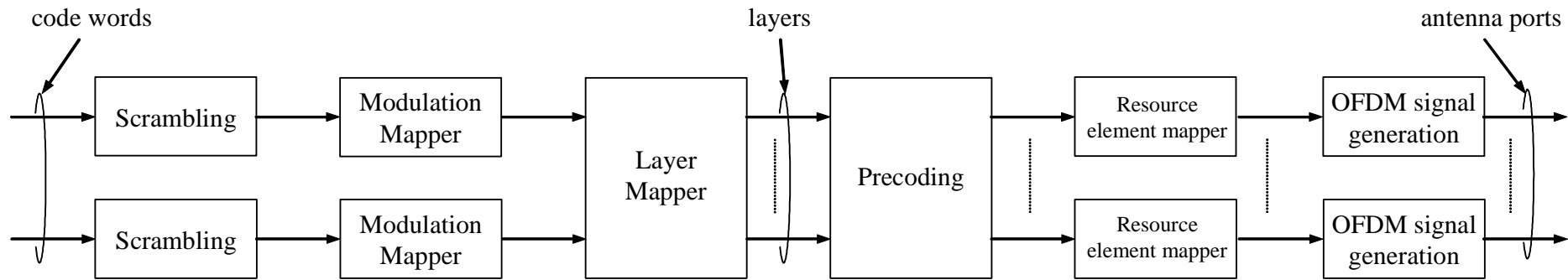

- scrambling of coded bits in each of the code words to be transmitted on a physical channel
- modulation of scrambled bits to generate complex-valued modulation symbols
- mapping of the complex-valued modulation symbols onto one or several transmission layers
- precoding of the complex-valued modulation symbols on each layer for transmission on the antenna ports
- mapping of complex-valued modulation symbols for each antenna port to resource elements
- generation of complex-valued time-domain OFDM signal for each antenna port

Modulation

Physical channel	Modulation schemes
PD SCH	QPSK, 16QAM, 64QAM
PMCH	QPSK, 16QAM, 64QAM

Physical channel	Modulation schemes
PBCH	QPSK

Physical channel	Modulation schemes
PCFICH	QPSK

Physical channel	Modulation schemes
PDCCH	QPSK

Physical channel	Modulation schemes
PHICH	BPSK

DL Layer Mapping and Precoding

- Explained in MIMO session

BCH on PBCH

- To broadcast a certain set of cell and/or system-specific information
Requirement to be broadcast in the entire coverage area of the cell
- Physical Layer Model for BCH transmission
 - Single (fixed-size) transport block per TTI (40 ms)
 - No HARQ, Tail biting convolution code
 - Cell-specific scrambling, QPSK only, Tx diversity(1,2,4)
 - 6 RBs = 72 subcarriers (excluding DC)

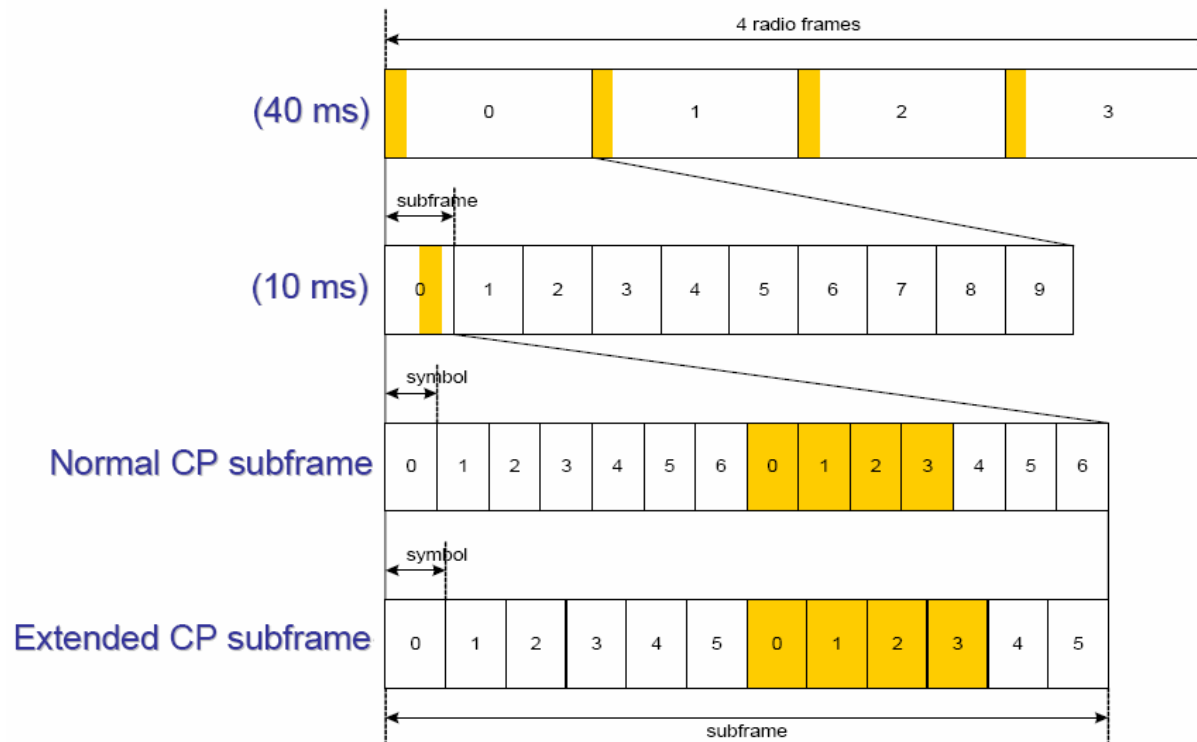

PDCCH

- First n OFDM symbols
- **Scheduling assignment**
 - Transport format, resource allocation, HARQ info related to DL-SCH, PCH
 - Transport format, resource allocation, HARQ info related to UL-SCH
- Aggregation of Control Channel Elements (CCE, e.g. 36RE in 5MHz)
- PDCCH formats (36.212)
- Cell-specific scrambling, QPSK modulation
- **Tx diversity**, the same antenna ports as PBCH
- RE quadruplet (4 REs)
 - 4 frequency-contiguous REs not used by RS, PCFICH or PHICH
 - Time first frequency next indexing
- Cell-specific cyclic shift mapping

* 김학성 (LGE), "3GPP LTE PHY Layer Specification and Technology", 제4차 차세대이동통신 단기강좌, Feb. 2008

PHICH

- HARQ ACK/NAK in response to UL transmission
- PHICH group
 - Multiple PHICHs mapped to the same REs (CDM & I/Q)
- HI codewords with length of 12 REs = 4 (spreading) x 3 (repetition)
- BPSK modulation with I/Q multiplexing
 - e.g. SF4 x I/Q = 8 PHICHs in normal CP
- Cell-specific scrambling
- Orthogonal sequence: Walsh sequence
 - Sequence Index = PHICH number within the PHICH group (0~7 or 0~4)
- Tx diversity, the same antenna ports as PBCH
- 3 groups of 4 contiguous REs (not used for RS and PCFICH)

* 김학성 (LGE), "3GPP LTE PHY Layer Specification and Technology", 제4차 차세대이동통신 단기강좌, Feb. 2008

DL OFDM Signal Generation

- OFDM Parameters

$$0 \leq t < (N_{CP,l} + N) \times T_s$$

$N = 2048$ for $\Delta f = 15\text{kHz}$
 $N = 4096$ for $\Delta f = 7.5\text{kHz}$

Table 6.12-1: OFDM parameters.

Configuration		Cyclic prefix length $N_{CP,l}$
Normal cyclic prefix	$\Delta f = 15 \text{ kHz}$	160 for $l = 0$ 144 for $l = 1, 2, \dots, 6$
	$\Delta f = 7.5 \text{ kHz}$	1024 for $l = 0, 1, 2$
Extended cyclic prefix	$\Delta f = 15 \text{ kHz}$	512 for $l = 0, 1, \dots, 5$
	$\Delta f = 7.5 \text{ kHz}$	1024 for $l = 0, 1, 2$

- Check with resource block parameters
 - $(160+2048) \times T_s = 71.88\mu\text{s}$
 - $(144+2048) \times T_s = 71.35\mu\text{s}$
 - $71.88\mu\text{s} + 71.35\mu\text{s} \times 6 = 0.5\text{ms}$
- Normal Cyclic Prefix = 160 $T_s = 5.2 \mu\text{s}$
- Extended Cyclic Prefix = 512 $T_s = 16.7 \mu\text{s}$
- Extended Cyclic Prefix for MBMS = 1024 $T_s = 33.3 \mu\text{s}$

UL Physical Channels & Signals

- PUSCH (Physical Uplink Shared Channel)
 - Carries UL-SCH
- PUCCH (Physical Uplink Control Channel)
 - Carries HARQ ACK/NAKs in response to DL transmission
 - Carries Scheduling Request (SR)
 - Carries CQI, PMI and RI
- PRACH (Physical Random Access Channel)
 - Carries the random access preamble
- UL Signals
 - An uplink physical signal is used by the physical layer but does not carry information originating from higher layers
 - UL RS (Uplink Reference Signal) for PUSCH, PUCCH
 - UL Sounding RS not associated with PUSCH, PUCCH transmission

UL Slot Structure

- $N_{\text{RB}}^{\text{UL}}$: Uplink bandwidth configuration, expressed in units of $N_{\text{sc}}^{\text{RB}}$
- $N_{\text{sc}}^{\text{RB}}$: Resource block size in the frequency domain, expressed as a number of subcarriers
- $N_{\text{symb}}^{\text{UL}}$: Number of SC-FDMA symbols in an uplink slot

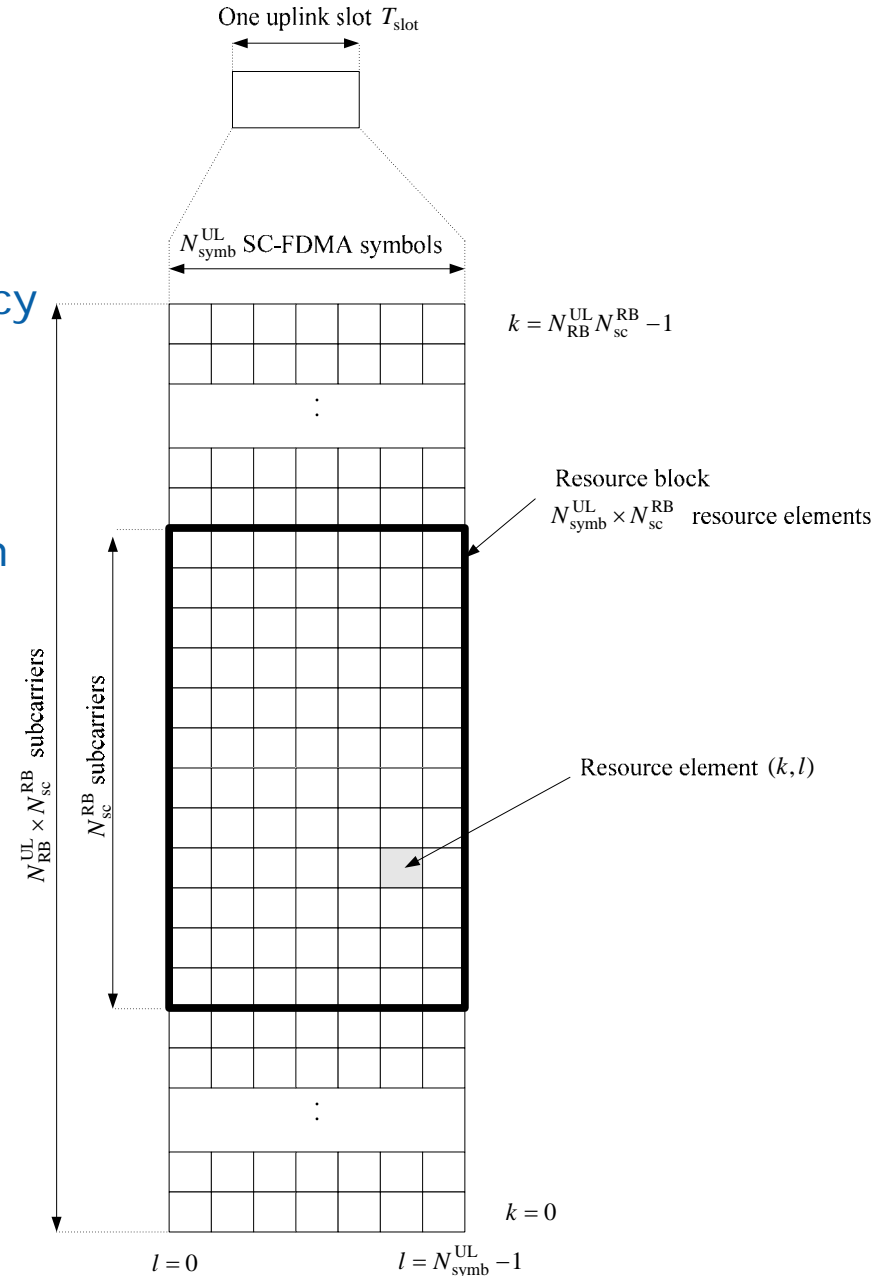

Definitions

- Resource Grid

- Defined as $N_{RB}^{UL} N_{sc}^{RB}$ subcarriers in frequency domain and N_{symb}^{UL} SC-FDMA symbols in time domain
- The quantity N_{RB}^{UL} depends on the UL transmission BW configured in the cell and shall fulfill $6 \leq N_{RB}^{UL} \leq 110$
- The set of allowed values for N_{RB}^{UL} is given by TS 36.101, TS 36.104

- Resource Block

- Defined as N_{sc}^{RB} “consecutive” subcarriers in frequency domain and N_{symb}^{UL} “consecutive” SC-FDMA symbols in time domain
- Corresponding to one slot in the time domain and 180 kHz in the frequency domain

Table 5.2.3-1: Resource block parameters.

Configuration	N_{sc}^{RB}	N_{symb}^{UL}
Normal cyclic prefix	12	7
Extended cyclic prefix	12	6

- Resource Element

- Uniquely defined by the index pair (k, l) in a slot where $k = 0, \dots, N_{RB}^{UL} N_{sc}^{RB} - 1$ and $l = 0, \dots, N_{symb}^{UL} - 1$ are the indices in the frequency and time domain, respectively

Physical Layer Processing of PUSCH

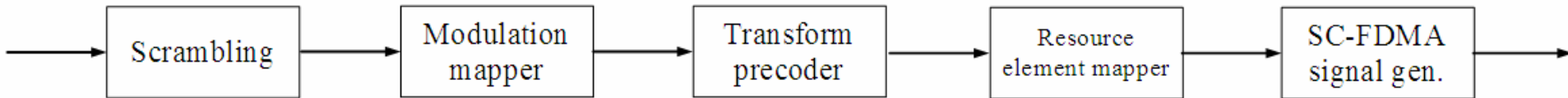

- Scrambling
- Modulation of scrambled bits to generate complex-valued modulation symbols
- Transform precoding to generate complex-valued modulation symbols
- Mapping of complex-valued modulation symbols to resource elements
- Generation of complex-valued time-domain SC-FDMA signal for each antenna port

PUCCH

- Carries ACK/NACK, CQI and SR (Scheduling Request)
- Modulation by CAZAC CS sequences (+ Orthogonal Covering)
- Symbol mapping of BPSK or QPSK
- PUCCH is never transmitted simultaneously with PUSCH from the same UE
- 2 consecutive PUCCH slots in Time-Frequency Hopping at the slot boundary

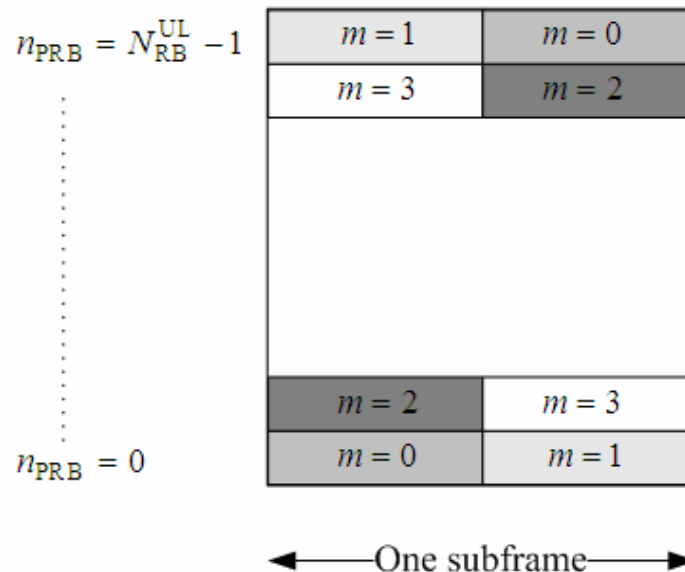

Figure 5.4.3-1: Mapping to physical resource blocks for PUCCH.

UL SC-FDMA Signal Generation

- This section applies to all uplink physical signals and physical channels except the physical random access channel
- SC-FDMA parameters

$$0 \leq t < (N_{CP,l} + N) \times T_s \quad \text{where } N = 2048$$

Table 5.6-1: SC-FDMA parameters.

Configuration	Cyclic prefix length $N_{CP,l}$
Normal cyclic prefix	160 for $l = 0$ 144 for $l = 1, 2, \dots, 6$
Extended cyclic prefix	512 for $l = 0, 1, \dots, 5$

- Check with numbers in Table 5.2.3-1.
 - $\{(160+2048) \times T_s\} + 6 \times \{(144+2048) \times T_s\} = 0.5 \text{ ms}$
 - $6 \times \{(512+2048) \times T_s\} = 0.5 \text{ ms}$

PRACH

- Five types of preamble formats
- 6RB (72 subcarriers)
- Higher layers control the preamble format
- Preamble format is given below

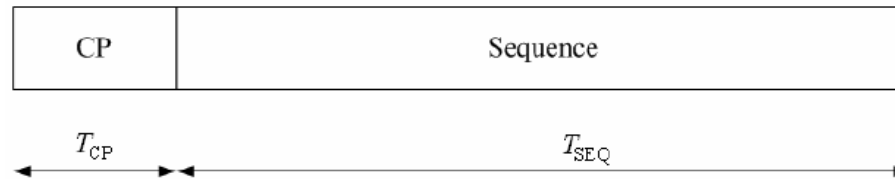

Table 5.7.1-1: Random access preamble parameters.

Preamble format	T_{CP}	T_{SEQ}
0	$3152 \times T_s$	$24576 \times T_s$
1	$21012 \times T_s$	$24576 \times T_s$
2	$6224 \times T_s$	$2 \times 24576 \times T_s$
3	$21012 \times T_s$	$2 \times 24576 \times T_s$
4 (frame structure type 2 only)	$0 \times T_s$	$4096 \times T_s$

* 김학성 (LGE), "3GPP LTE PHY Layer Specification and Technology", 제4차 차세대이동통신 단기강좌, Feb. 2008

Random Access Procedure*

- #1: PRACH Preamble Transmission
 - One of 64 sequences partitioned from 838 ZC-ZCZs on a cell-basis
- #2: RA Response
 - Timing Adjustment, Temp_ID, Resource Allocation Grant for M3
- #3: RRC Signalling
 - Mobile terminal ID (C-RNTI if connected before)
- #4: Contention Resolution Message to the UE

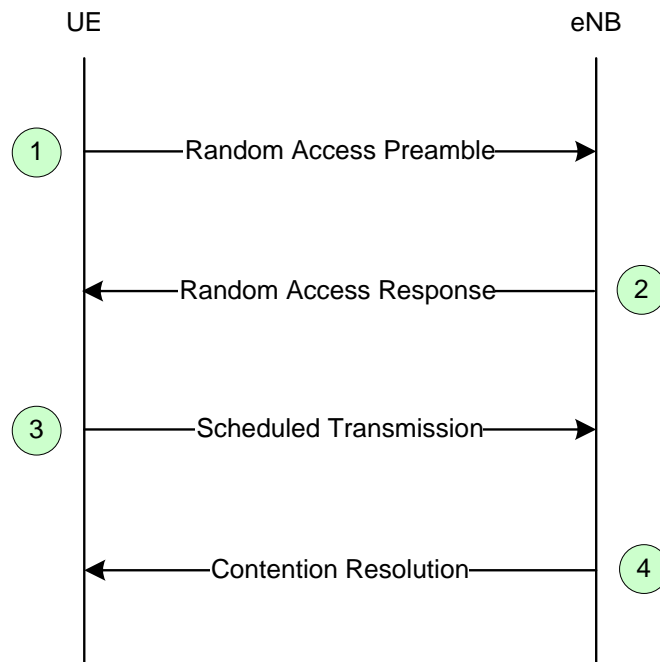

Interaction model between L1 and L2/3 for Random Access Procedure*

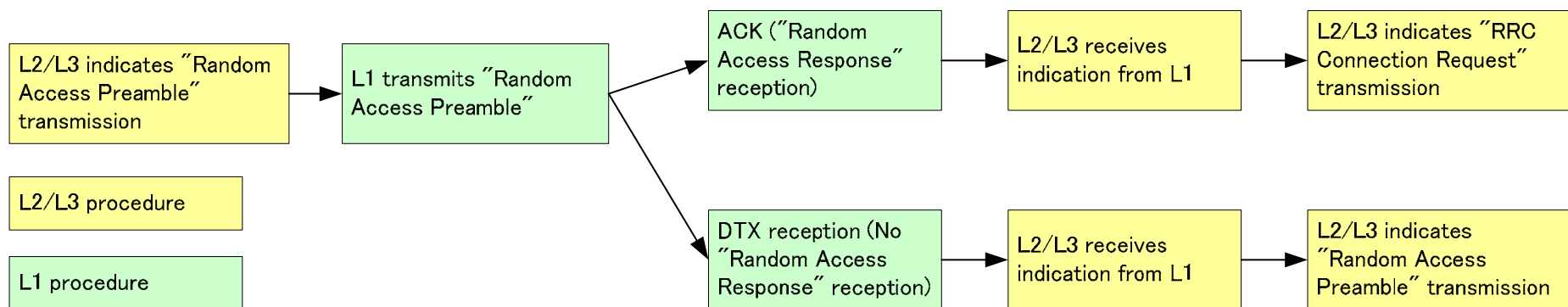

* 3GPP TS 36.300, E-UTRA and E-UTRAN; Overall description; Stage 2, Release 8, V8.4.0, March 2008.

DL Reference Signals

- Three types of downlink reference signals are defined:
 - Cell-specific reference signals, associated with non-MBSFN transmission
 - MBSFN reference signals, associated with MBSFN transmission
 - UE-specific reference signals
- **Objectives**
 - Downlink channel quality measurement
 - Downlink channel estimation
 - Cell search and initial acquisition
- Numerology
 - Use of Known reference symbols
 - Insertion in the first and third last OFDM symbol of each slot
 - One RS per DL antenna port (1, 2, or 4)

Cell-Specific Reference Signals

- Normal and extended CP
 - 504 unique Cell ID:
 - 168(N1) Cell ID groups, 3 (N2) Cell ID within each group
 - Cell ID = 3xN1+N2 = 0 ~ 503 index
 - 504 pseudo-random sequences
 - One to one mapping between the Cell ID and Pseudo-random sequences
 - Transmit on antenna port {0, 1, 2, 3}
 - Cell-specific Frequency Shift (N1 mod 6) (effective with RS boosting)
 - 1 RE shift from current RS position in case of next Cell ID index
- Pseudo-random sequence generation

$$r_{l,n_s}(m) = \frac{1}{\sqrt{2}}(1 - 2 \cdot c(2m)) + j \frac{1}{\sqrt{2}}(1 - 2 \cdot c(2m+1)), \quad m = 0, 1, \dots, 2N_{\text{RB}}^{\text{max,DL}} - 1$$

- n_s is the slot number within a radio frame.
- l is the OFDM symbol number within the slot.
- The pseudo-random sequence $c(i)$ is a length-31 Gold sequence.

DL Reference Signals Mapping

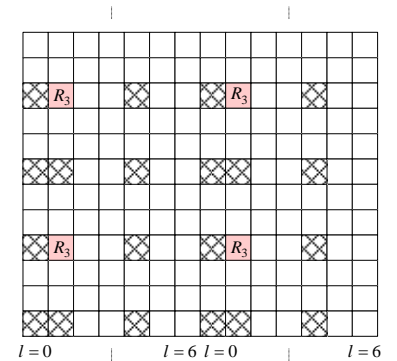
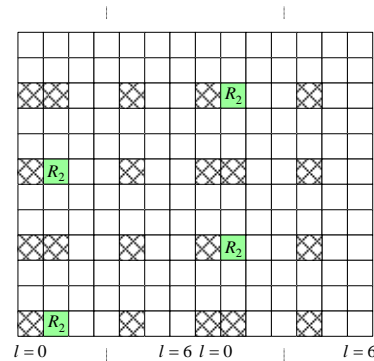
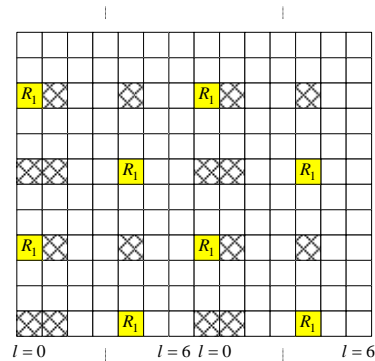
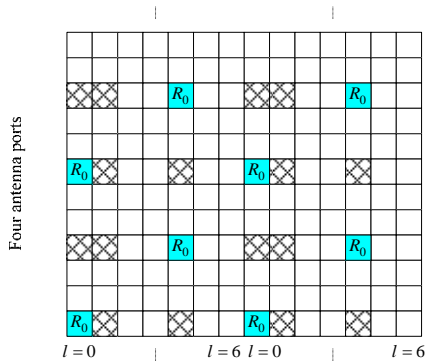
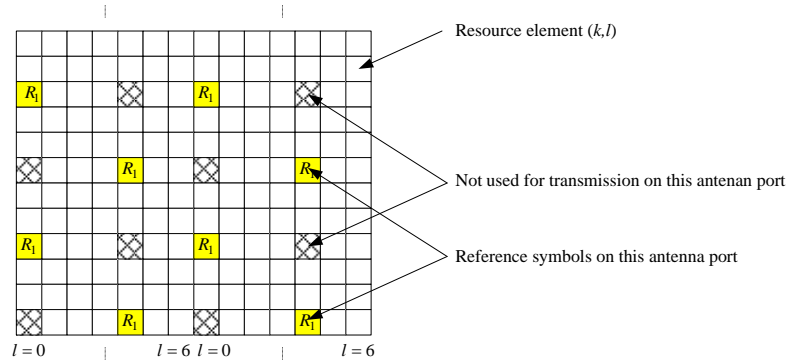
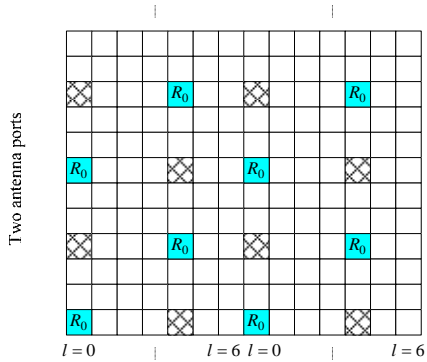
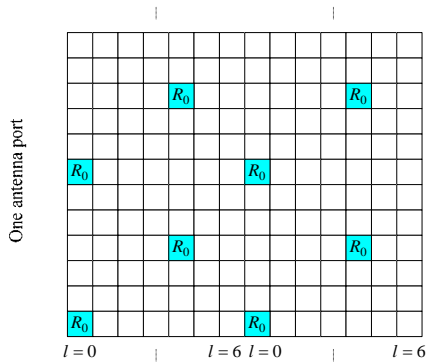

← even-numbered slots odd-numbered slots →

← even-numbered slots odd-numbered slots →

← even-numbered slots odd-numbered slots →

← even-numbered slots odd-numbered slots →

Antenna port 0

Antenna port 1

Antenna port 2

Antenna port 3

UL Reference Signals

- Two types of uplink reference signals are supported:
 - Demodulation reference signal, associated with transmission of PUSCH or PUCCH
 - Sounding reference signal, not associated with transmission of PUSCH or PUCCH
- The same set of base sequences is used for demodulation and sounding reference signals

Synchronization Signals

- 504 unique physical-layer cell identities
 - 168 unique physical-layer cell-identity groups (0~167)
 - 3 physical-layer identity within physical-layer cell-identity group (0~2)
- Primary synchronization signal
 - The sequence used for the primary synchronization signal is generated from a frequency-domain Zadoff-Chu sequence

$$d_u(n) = \begin{cases} e^{-j\frac{\pi un(n+1)}{63}} & n = 0,1,\dots,30 \\ e^{-j\frac{\pi u(n+1)(n+2)}{63}} & n = 31,32,\dots,61 \end{cases}$$

$N_{ID}^{(2)}$	Root index u
0	25
1	29
2	34

- For frame structure type 1, the primary synchronization signal shall be mapped to the last OFDM symbol in slots 0 and 10
- The sequence shall be mapped to the resource elements according to

$$a_{k,l} = d(n), \quad k = n - 31 + \frac{N_{RB}^{DL} N_{sc}^{RB}}{2}, \quad l = N_{symb}^{DL} - 1, \quad n = 0, \dots, 61$$

Synchronization Signals – cont'd

- Secondary synchronization signal
 - The sequence used for the second synchronization signal is an interleaved concatenation of two length-31 binary sequences
 - The concatenated sequence is scrambled with a scrambling sequence given by the primary synchronization signal
 - The combination of two length-31 sequences defining the secondary synchronization signal differs between subframe 0 and subframe 5 according to

$$d(2n) = \begin{cases} s_0^{(m_0)}(n)c_0(n) & \text{in subframe 0} \\ s_1^{(m_1)}(n)c_0(n) & \text{in subframe 5} \end{cases}$$
$$d(2n+1) = \begin{cases} s_1^{(m_1)}(n)c_1(n)z_1^{(m_0)}(n) & \text{in subframe 0} \\ s_0^{(m_0)}(n)c_1(n)z_1^{(m_1)}(n) & \text{in subframe 5} \end{cases}$$

where $0 \leq n \leq 30$

Synchronization Signals – cont'd

Table 6.11.2.1-1: Mapping between physical-layer cell-identity group $N_{ID}^{(1)}$ and the indices m_0 and m_1 .

$N_{ID}^{(1)}$	m_0	m_1	$N_{ID}^{(1)}$	m_0	m_1	$N_{ID}^{(1)}$	m_0	m_1	$N_{ID}^{(1)}$	m_0	m_1	$N_{ID}^{(1)}$	m_0	m_1
0	0	1	34	4	6	68	9	12	102	15	19	136	22	27
1	1	2	35	5	7	69	10	13	103	16	20	137	23	28
2	2	3	36	6	8	70	11	14	104	17	21	138	24	29
3	3	4	37	7	9	71	12	15	105	18	22	139	25	30
4	4	5	38	8	10	72	13	16	106	19	23	140	0	6
5	5	6	39	9	11	73	14	17	107	20	24	141	1	7
6	6	7	40	10	12	74	15	18	108	21	25	142	2	8
7	7	8	41	11	13	75	16	19	109	22	26	143	3	9
8	8	9	42	12	14	76	17	20	110	23	27	144	4	10
9	9	10	43	13	15	77	18	21	111	24	28	145	5	11
10	10	11	44	14	16	78	19	22	112	25	29	146	6	12
11	11	12	45	15	17	79	20	23	113	26	30	147	7	13
12	12	13	46	16	18	80	21	24	114	0	5	148	8	14
13	13	14	47	17	19	81	22	25	115	1	6	149	9	15
14	14	15	48	18	20	82	23	26	116	2	7	150	10	16
15	15	16	49	19	21	83	24	27	117	3	8	151	11	17
16	16	17	50	20	22	84	25	28	118	4	9	152	12	18
17	17	18	51	21	23	85	26	29	119	5	10	153	13	19
18	18	19	52	22	24	86	27	30	120	6	11	154	14	20
19	19	20	53	23	25	87	0	4	121	7	12	155	15	21
20	20	21	54	24	26	88	1	5	122	8	13	156	16	22
21	21	22	55	25	27	89	2	6	123	9	14	157	17	23
22	22	23	56	26	28	90	3	7	124	10	15	158	18	24
23	23	24	57	27	29	91	4	8	125	11	16	159	19	25
24	24	25	58	28	30	92	5	9	126	12	17	160	20	26
25	25	26	59	0	3	93	6	10	127	13	18	161	21	27
26	26	27	60	1	4	94	7	11	128	14	19	162	22	28
27	27	28	61	2	5	95	8	12	129	15	20	163	23	29
28	28	29	62	3	6	96	9	13	130	16	21	164	24	30
29	29	30	63	4	7	97	10	14	131	17	22	165	0	7
30	0	2	64	5	8	98	11	15	132	18	23	166	1	8
31	1	3	65	6	9	99	12	16	133	19	24	167	2	9
32	2	4	66	7	10	100	13	17	134	20	25	-	-	-
33	3	5	67	8	11	101	14	18	135	21	26	-	-	-

PSS

- Repeat the same sequence twice → **Half-frame timing**
- Cell ID detection within a cell ID group (3 hypotheses) → **Cell ID**
- Length-62 frequency-domain Zadoff-Chu sequence
- Antenna port not specified (any port)
- 6 RBs = 72 subcarriers (excluding DC)

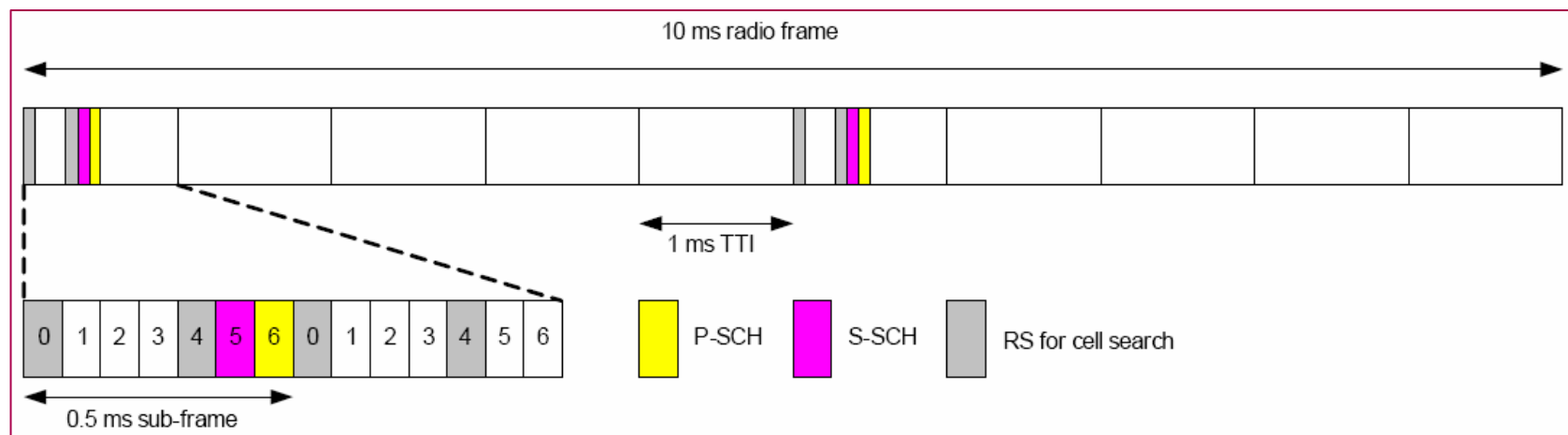
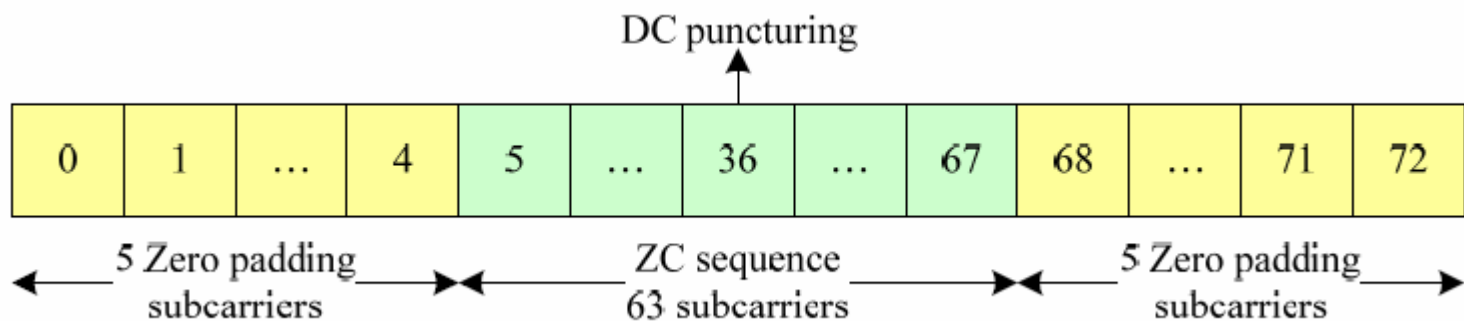

SSS

- Frame boundary detection (2 hypotheses) → **Frame timing**
- Cell ID group detection (168 hypotheses)
→ **Cell ID group / Pseudo-Random Sequence**
- CP detection (blind)
- Interleaved concatenation of two length-31 binary sequence
- The sequences defining the SSS **differs between slot 0 and slot 10**
- The same antenna port as for the primary sync signal
- 6 RBs = 72 subcarriers (excluding DC)

DC subcarrier

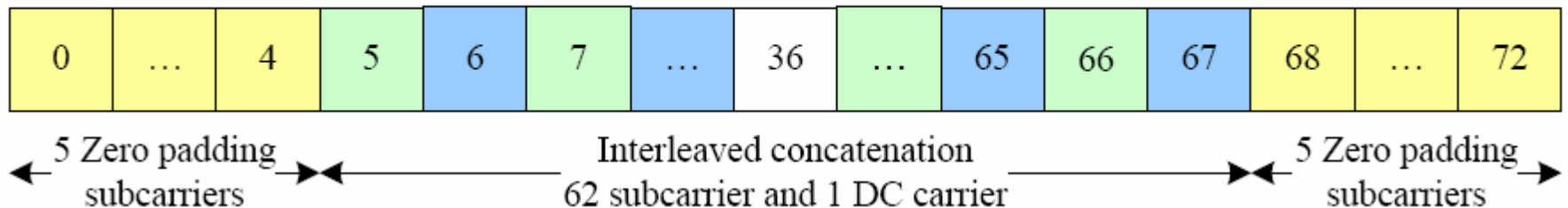

LTE Cell Search

- DL Signals used for cell search
 - Primary synchronization signals (P-SCH)
 - Secondary synchronization signals (SSCH)
 - Broadcasting channel (BCH)
 - To broadcast a certain set of cell and/or system-specific information
- PSCH
 - Carries 3 hypotheses (cell ID within a cell group ID)
- SSCH
 - 168 (cell gr. ID) x 2 (frame boundary) x N (antenna config. for PBCH) hypotheses

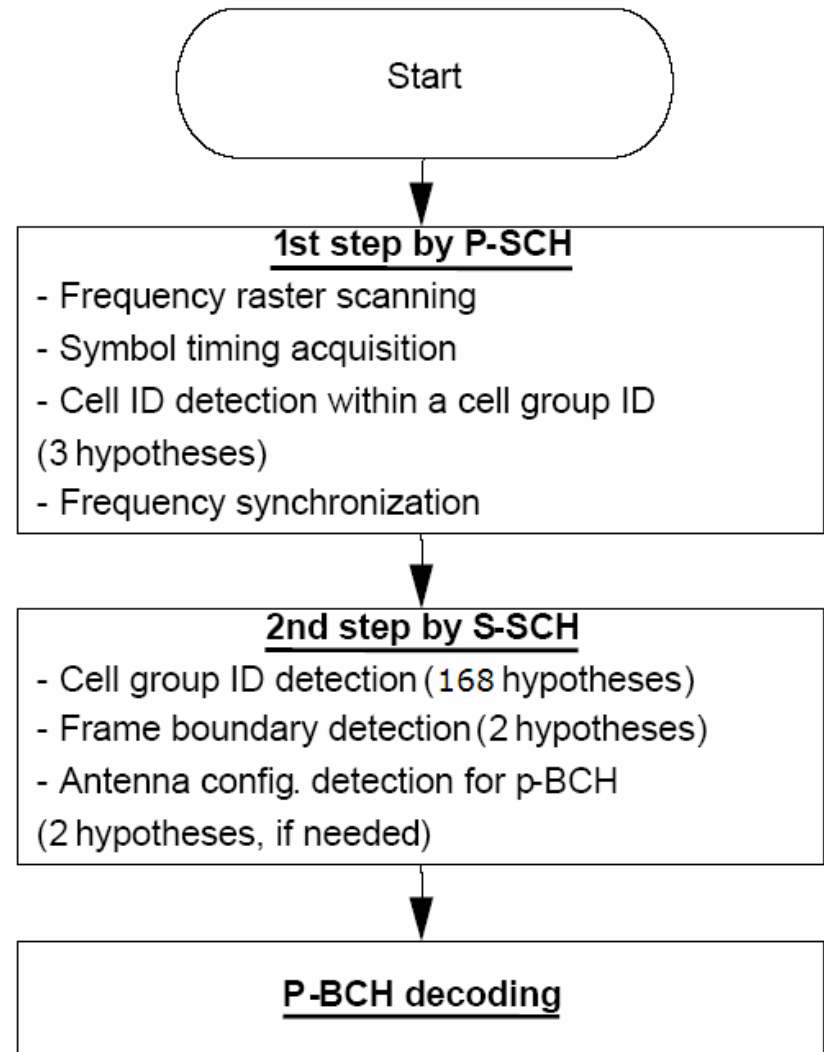

(cf) WCDMA Cell Search Procedure

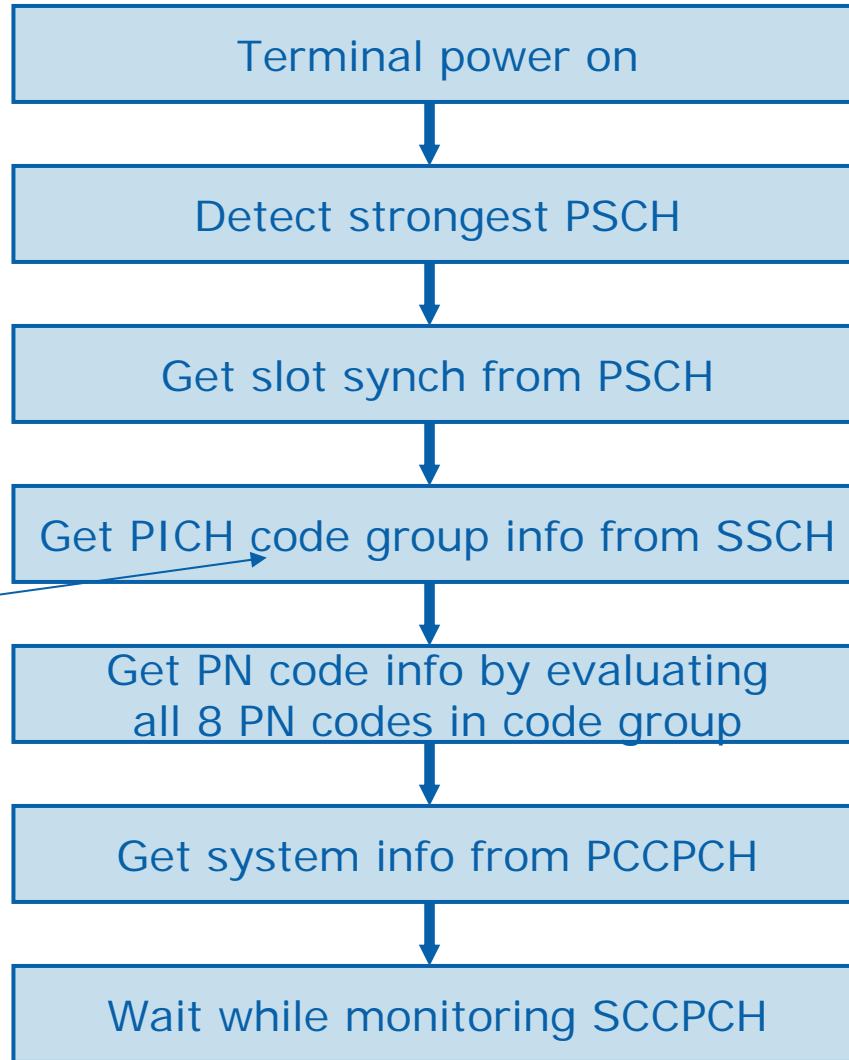

1 code group has 8 PN codes.
64 code groups have 512 PN codes in total.

LTE Cell Search – cont'd*

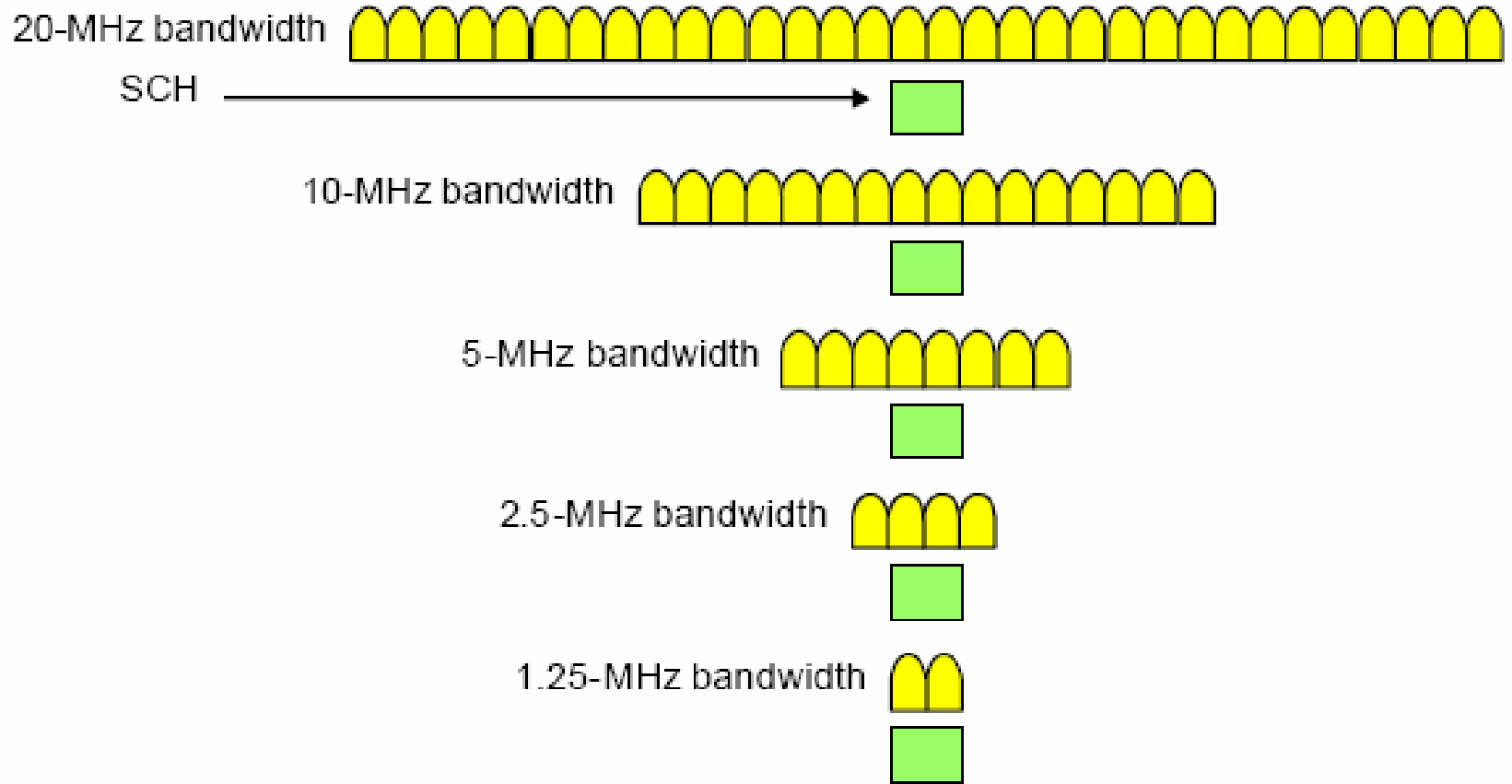

* 정재훈 (LGE), "Basics and Core Technologies of 3GPP LTE Physical Layer", 제3회 차세대 이동통신 기술 단기강좌, Aug. 2007

DL Frame Structure Type 1*

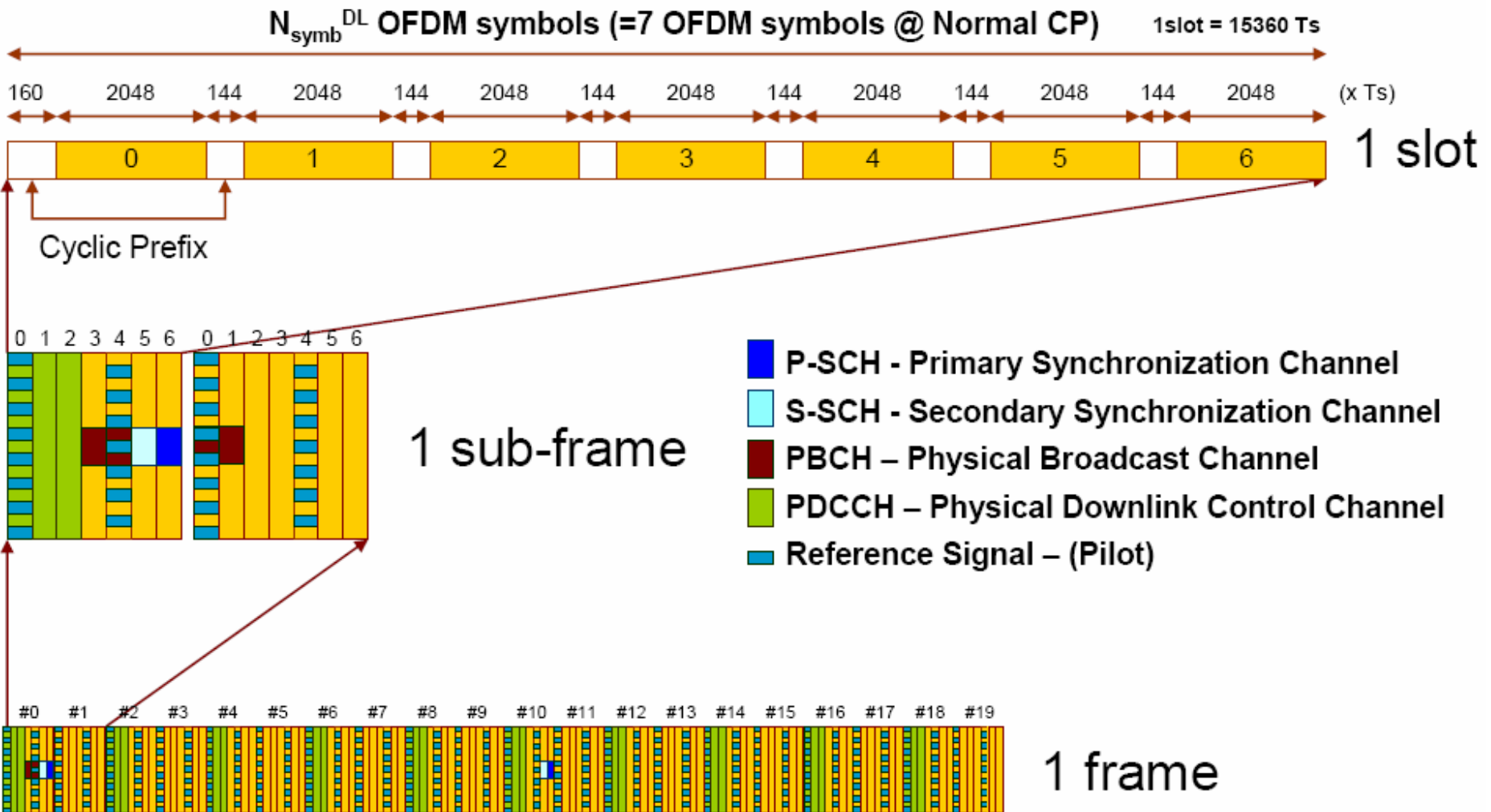

* Moray Rumney (Agilent),
 "Concepts of 3GPP LTE", Live
 Webinar, Sep. 20th, 2007.

DL Frame Structure Type 1 – cont'd*

- P-SCH - Primary Synchronization Channel
- S-SCH - Secondary Synchronization Channel
- PBCH – Physical Broadcast Channel
- PDCCH – Physical Downlink Control Channel
- Reference Signal – (Pilot)

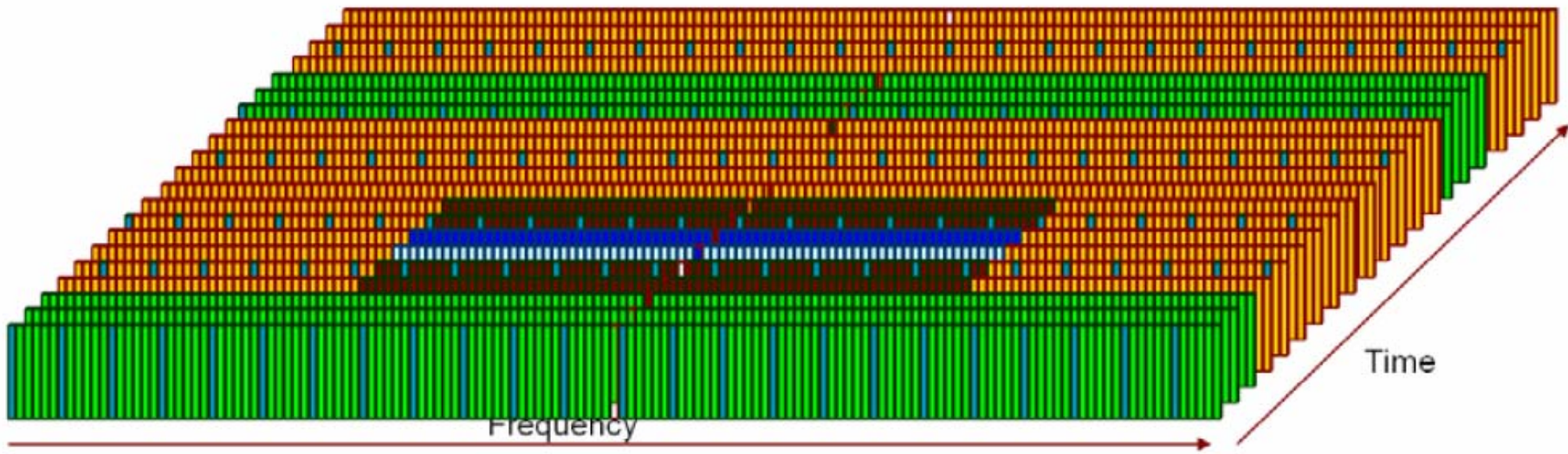
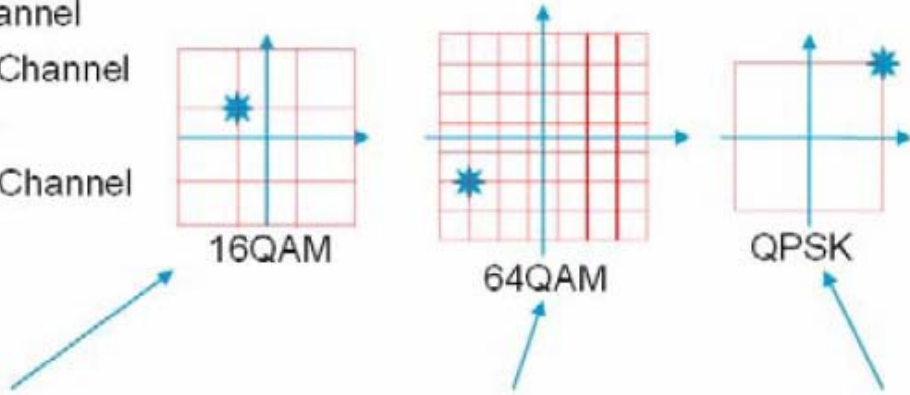

* Moray Rumney (Agilent),
 "Concepts of 3GPP LTE", Live
 Webinar, Sep. 20th, 2007.

UL Frame Structure Type 1*

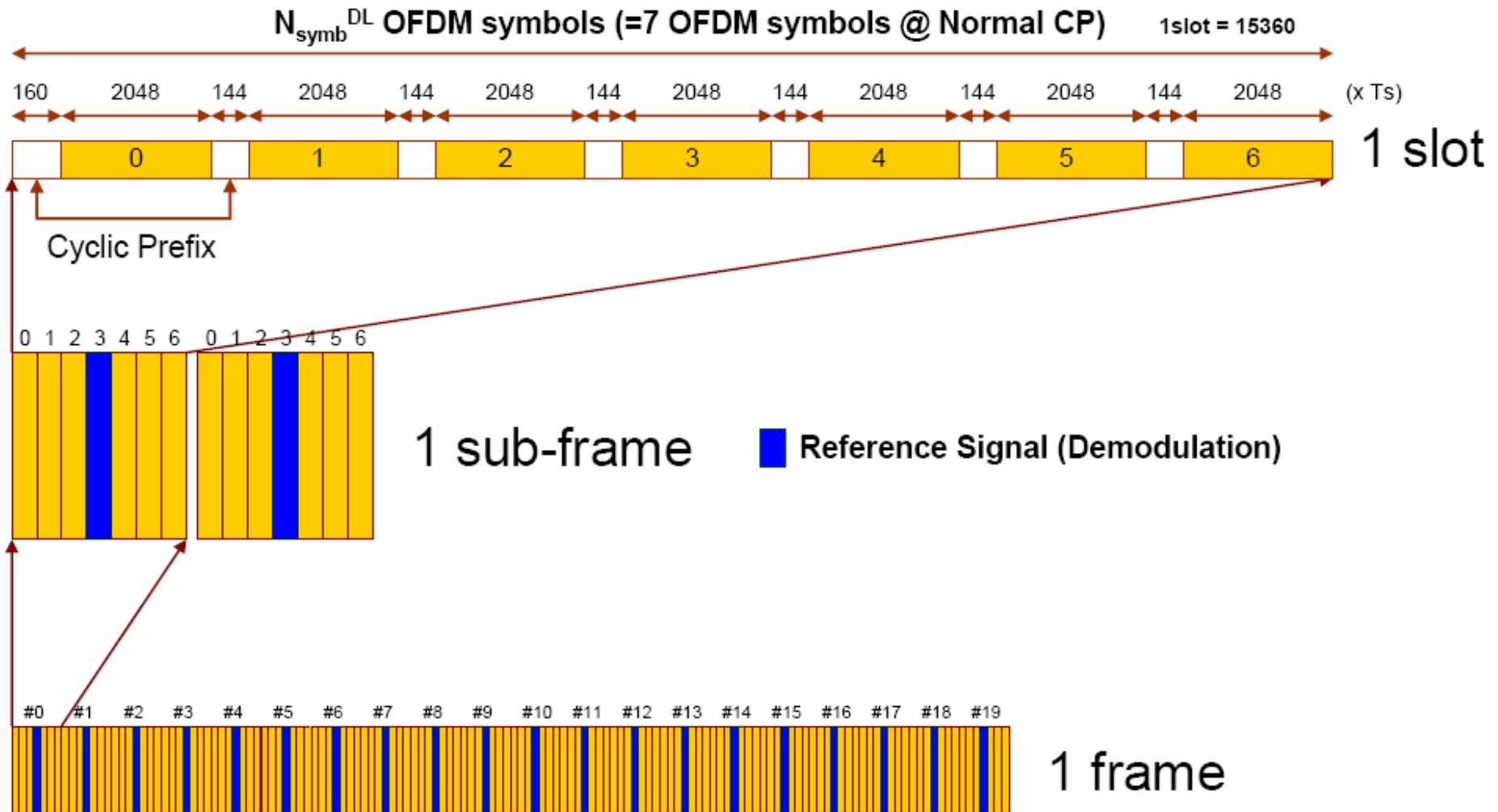

* Moray Rumney (Agilent),
 "Concepts of 3GPP LTE", Live
 Webinar, Sep. 20th, 2007.

UL Frame Structure Type 1 – cont'd*

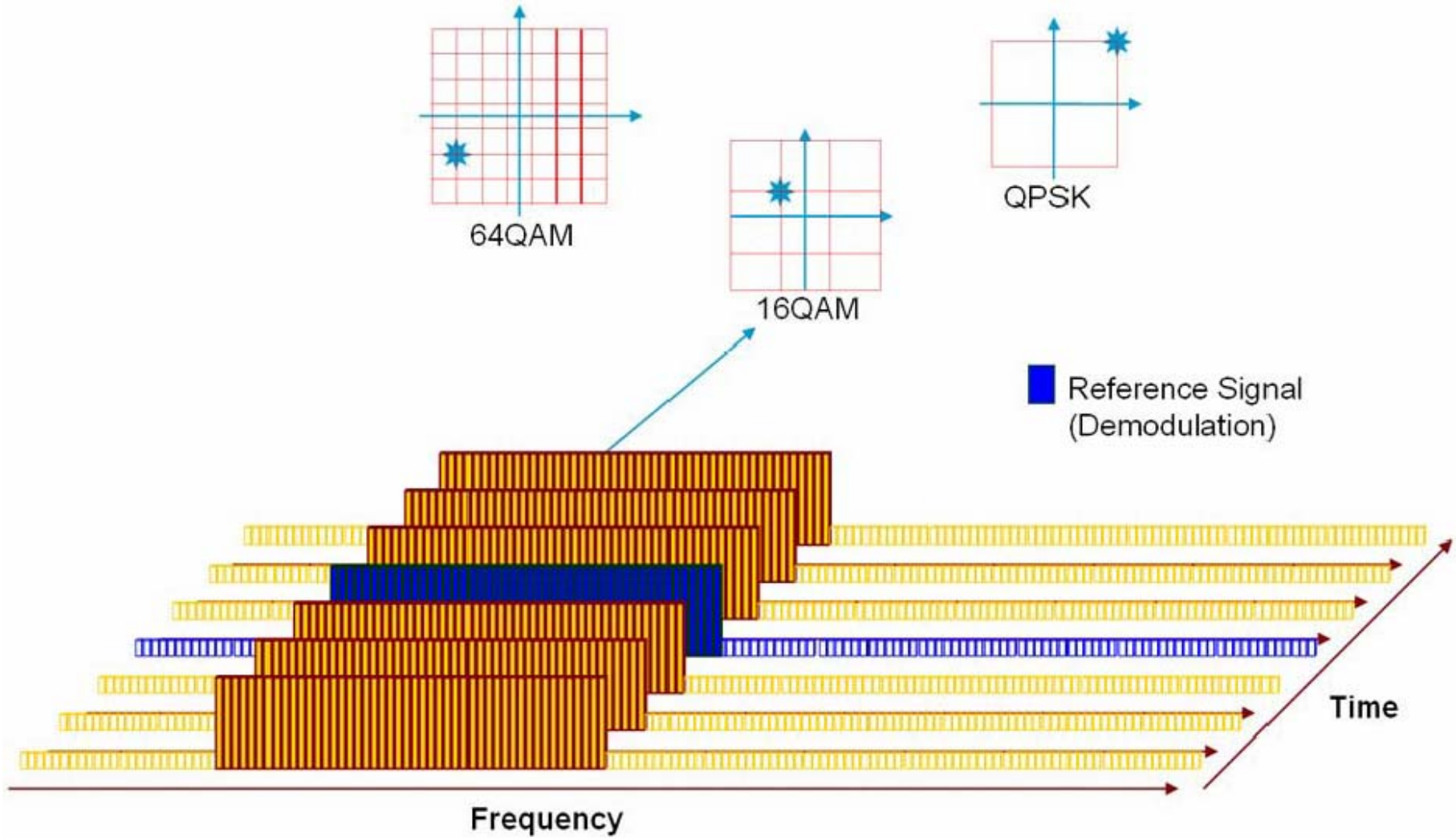

LTE Subcarrier Operation*

- Two Approaches
 - Distributed
 - Frequency diversity
 - “Not used anymore” for PUSCH transmission
 - Localized
 - Frequency selective gain with channel dependent scheduling (Multi-user diversity)

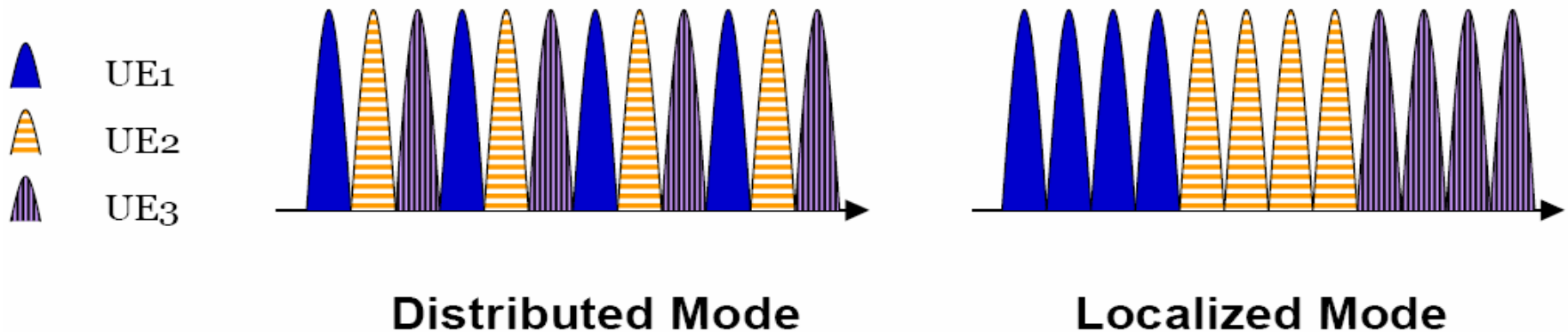

Distributed Mode

Localized Mode

* 오민석 (LGE), “3GPP LTE”, KRnet 2007, June 29 2007

LTE Scheduling

- Multiuser diversity
- Frequency diversity scheduling
 - UEs are allocated to distributed resource blocks (combs)
 - Not available in UL
- Frequency selective scheduling: user specific
 - Each UE is allocated its individual best part of the spectrum
 - Best use of the spectrum → OFDMA exploits channel capacity
 - Sufficient feedback information on channel conditions from UE required

LTE Link Adaptation*

- Purpose
 - Guarantee the required QoS of each UE
 - User data rate, packet error rate, and latency
 - Maximize the system throughput.
- Three Link Adaptation Techniques
 - Adaptive transmission bandwidth
 - Averaged channel conditions, UE capability and Required data rate considered
 - Fast Freq. Selective Fading → channel dependent scheduling
 - Transmission power control
 - Guarantee the required packet error rate and bit error rate
 - Tradeoff between fairness and system throughput
 - Adaptive modulation and channel coding rate (AMC)
 - Increases the achievable data rate (frequency efficiency) according to the channel conditions
- Considerations
 - Control Update Interval
 - Signaling overhead ↔ performance enhancement

* 정재훈 (LGE), "Basics and Core Technologies of 3GPP LTE Physical Layer", 제3회 차세대 이동통신 기술 단기강좌, Aug. 2007

Channel Coding

- Turbo code interleaver
 - QPP (quadratic polynomial permutation) interleaver
- Applied channel coding scheme

Table 5.1.3-1: Usage of channel coding scheme and coding rate for TrCHs

TrCH	Coding scheme	Coding rate
UL-SCH	Turbo coding	1/3
DL-SCH		
PCH		
MCH		
BCH	Tail biting convolutional coding	1/3

Table 5.1.3-2: Usage of channel coding scheme and coding rate for control information

Control Information	Coding scheme	Coding rate
DCI	Tail biting convolutional coding	1/3
CFI	Block code	1/16
HI	Repetition code	1/3
UCI	Block code	variable
	Tail biting convolutional coding	1/3

Transport Channels*

- Downlink
 - Broadcast Channel (BCH)
 - Downlink Shared Channel (DL-SCH)
 - Paging Channel (PCH)
 - Multicast Channel (MCH)
- Uplink
 - Uplink Shared Channel (UL-SCH)
 - Random Access Channel(s) (RACH)

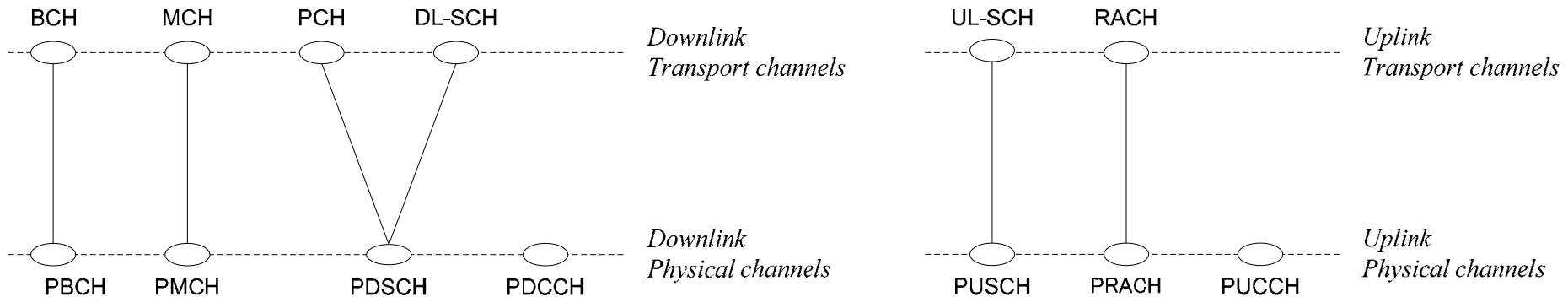

* 3GPP TS 36.300, E-UTRA and E-UTRAN; Overall description; Stage 2, Release 8, V8.4.0, March 2008.

Logical Channels

- Control Channels
 - Broadcast Control Channel (BCCH)
 - Paging Control Channel (PCCH)
 - Common Control Channel (CCCH)
 - Multicast Control Channel (MCCH)
 - Dedicated Control Channel (DCCH)
- Traffic Channels
 - Dedicated Traffic Channel (DTCH)
 - Multicast Traffic Channel (MTCH)

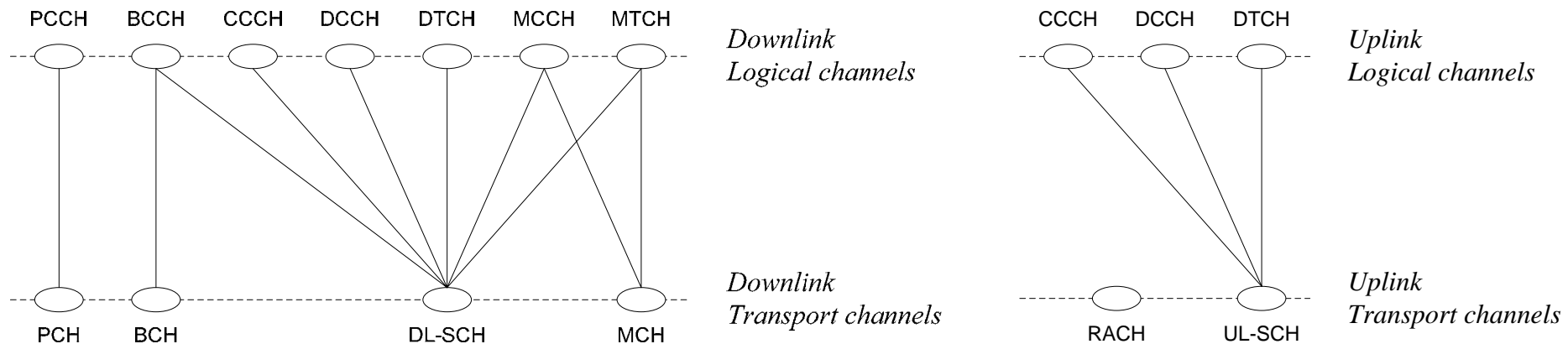

Guideline for E-UTRAN UE capabilities*

- The definition of the following UE classes are proposed

Note: For simplification reasons, the table only depict the UE capabilities in terms of uplink and downlink peak data rates supported. However, it should be noted that further discussion on other features is expected once the work progresses.

Table G-1: E-UTRAN UE Classes

Class	UL	DL
A	[50] Mbps	[100] Mbps
B	[25] Mbps	[50] Mbps
C	[2] Mbps	[2] Mbps

- It may require further discussion whether there be a need for an additional terminal class between 2 Mbps and 50 Mbps classes.
- The above given data rates are indicative and should be subject for further discussions in 3GPP RAN working groups.
- The definition of the required parameters/features is for further study for each of the classes. For instance, half-duplex UEs form a specific category that may be frequency band specific.

* 3GPP TS 36.300, E-UTRA and E-UTRAN; Overall description; Stage 2, Release 8, V8.4.0, March 2008.

3GPP SAE

SAE (System Architecture Evolution)

SAE focus is on:

- enhancement of Packet Switched technology to cope with rapid growth in IP traffic
 - higher data rates
 - lower latency
 - packet optimised system
- through
 - fully IP network
 - simplified network architecture
 - distributed control

Functional Split b/w E-UTRAN and EPC

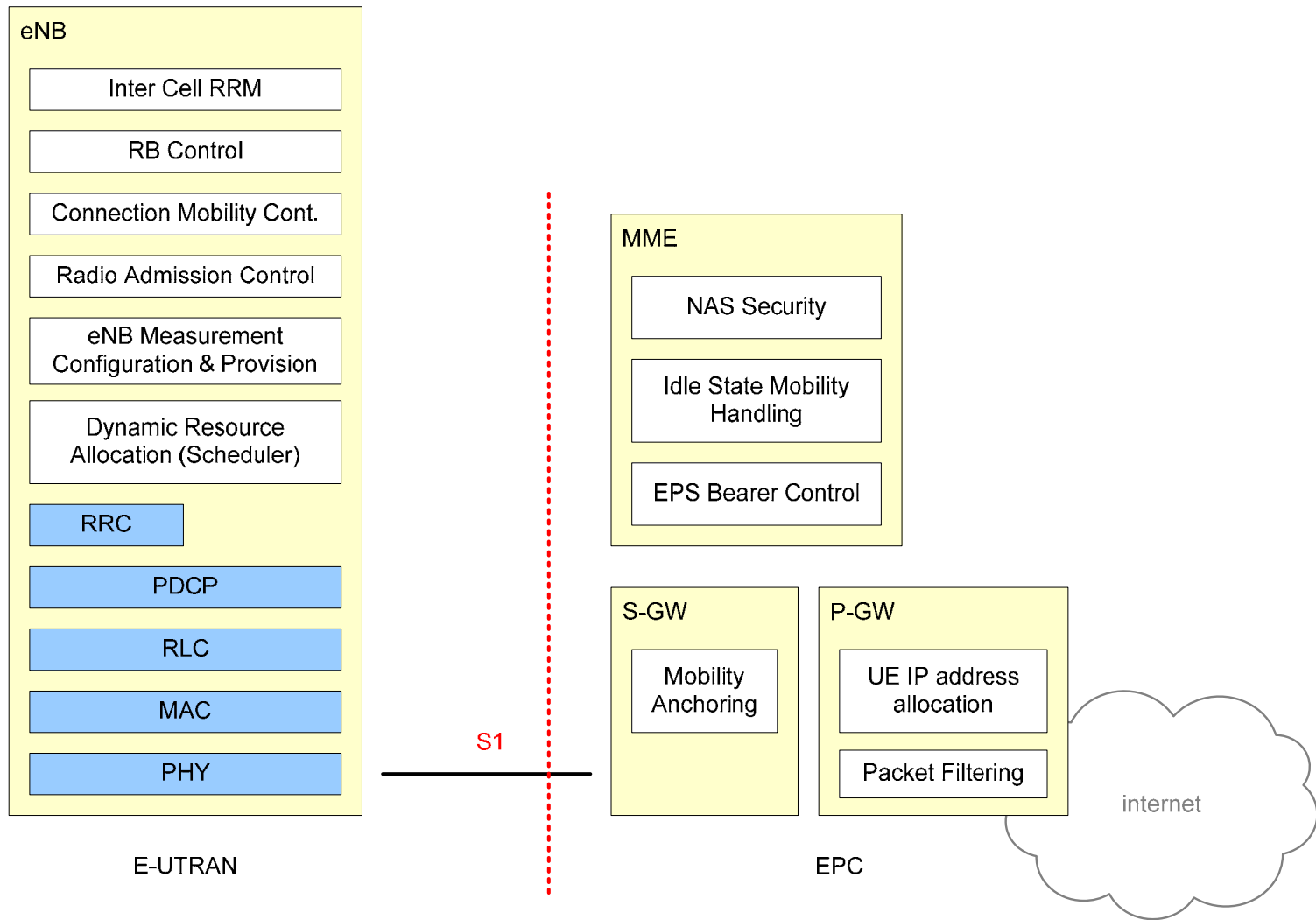

Functional Split

- eNB
 - Functions for **Radio Resource Management**: Radio Bearer Control, **Radio Admission Control**, Connection Mobility Control, Dynamic allocation of resources to UEs in both uplink and downlink (scheduling);
 - **IP header compression** and **encryption** of user data stream;
 - Selection of an MME at UE attachment when no routing to an MME can be determined from the information provided by the UE;
 - **Routing of User Plane data towards Serving Gateway**;
 - Scheduling and transmission of paging messages (originated from the MME);
 - Scheduling and transmission of broadcast information (originated from the MME or O&M);
 - Measurement and measurement reporting configuration for mobility and scheduling.
- MME: 3GPP TS 23.401
 - NAS signalling;
 - NAS signalling security;
 - Inter CN node signalling for mobility between 3GPP access networks (terminating S3);
 - UE Reachability in ECM-IDLE state (including control and execution of paging retransmission);
 - Tracking Area list management;
 - PDN GW and Serving GW selection;
 - MME selection for handovers with MME change;
 - **SGSN selection for handovers to 2G or 3G 3GPP access networks**;
 - Roaming (S6a towards home HSS);
 - Authentication;
 - Bearer management functions including dedicated bearer establishment.

Functional Split – cont'd

- Serving Gateway (S-GW): 3GPP TS 23.401
 - Local Mobility Anchor point for inter-eNodeB handover;
 - Assist the eNodeB reordering function during inter-eNodeB handover
 - Mobility anchoring for inter-3GPP mobility
 - ECM-IDLE mode downlink packet buffering and initiation of network triggered service request procedure;
 - Lawful Interception;
 - Packet routing and forwarding;
 - Transport level packet marking in the uplink and the downlink
 - Accounting on user and QCI granularity for inter-operator charging;
 - UL and DL charging per UE, PDN, and QCI (e.g. for roaming with home routed traffic).
- PDN Gateway (P-GW): 3GPP TS 23.401
 - Per-user based packet filtering (by e.g. deep packet inspection);
 - Lawful Interception;
 - UE IP address allocation;
 - Transport level packet marking in the uplink and downlink
 - UL and DL service level charging, gating control, and rate enforcement as defined in TS 23.203
 - DL rate enforcement based on AMBR
 - DHCPv4 (server and client) and DHCPv6 (client, relay and server) functions;
 - The network does not support PPP bearer type in this version of the specification. Pre-Release 8 PPP functionality of a GGSN may be implemented in the PDN GW.

Non-roaming architecture for 3GPP accesses*

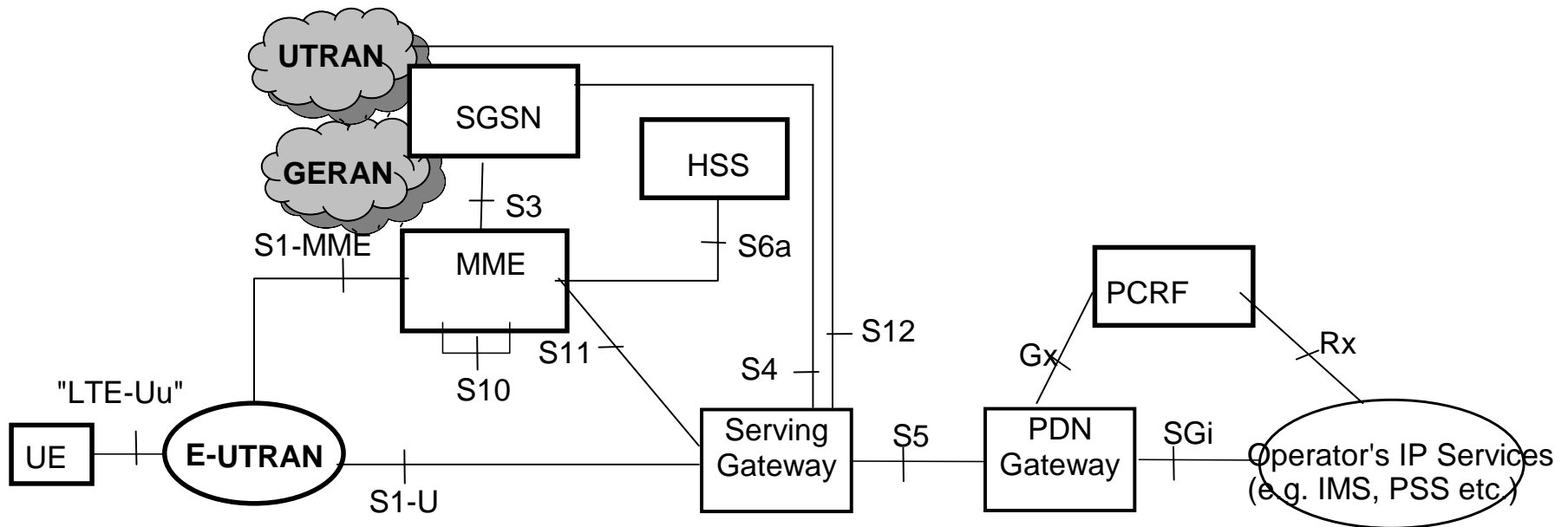

* TS 23.401, GPRS enhancements for E-UTRAN access (Release 8), V8.1.0, March 2008

Heterogeneous access system mobility*

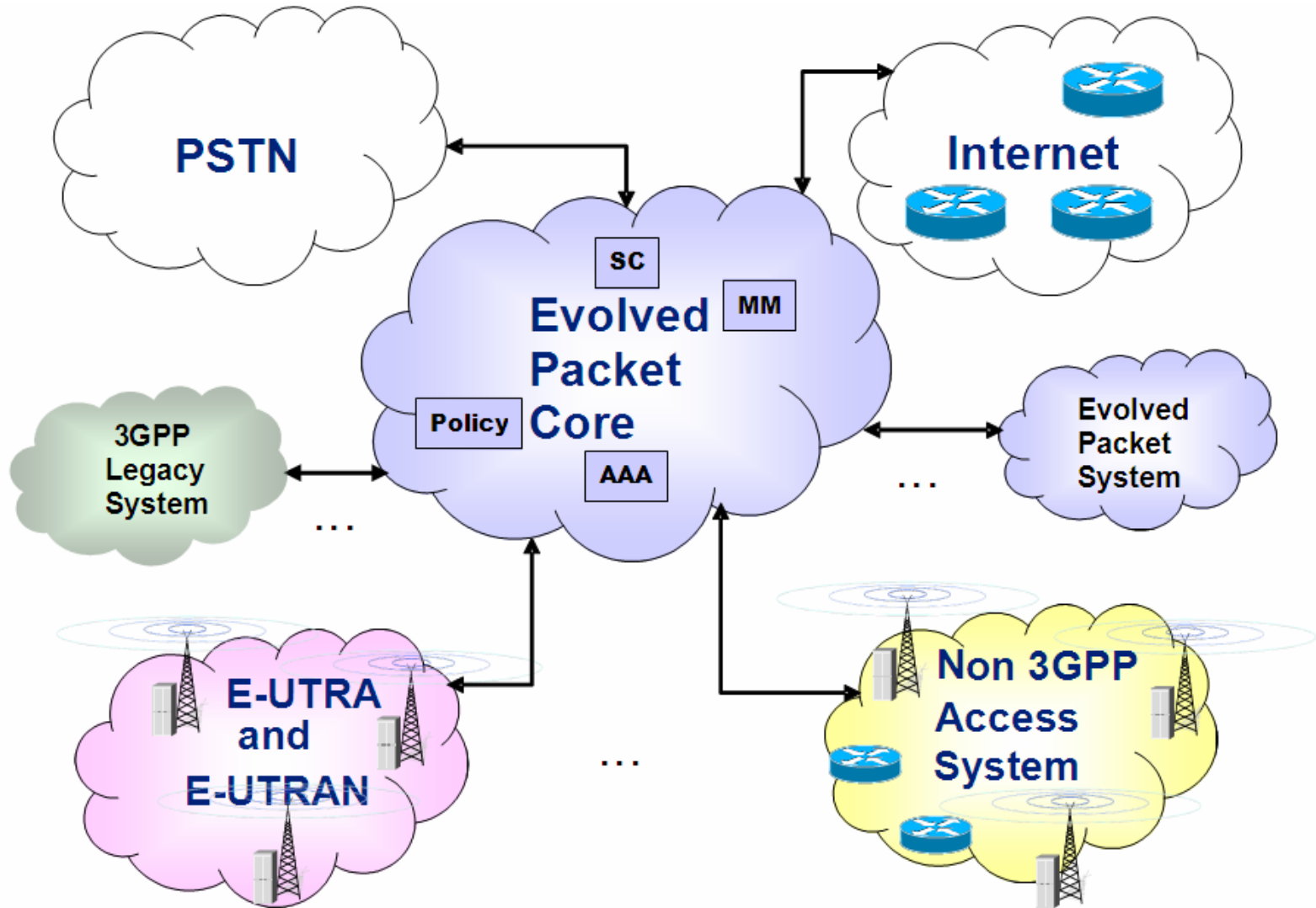

* 3GPP TS 22.278, Service requirements for the Evolved Packet System (EPS), Release 8, V8.4.0, Dec. 2007

Mobility b/w E-UTRAN and WiMAX*

The following high level requirements will be supported:

- It shall be possible for the operator to provide the UE with access network information pertaining to supported WiMAX access technologies. The access network information may also include operator preferences based on available WiMAX access technologies. The information may be restricted to the access technologies, based on the UE's current location and preferences
- The evolved 3GPP system shall support bidirectional service continuity between WiMAX and E-UTRAN.
- The evolved 3GPP system shall support seamless voice service continuity between E-UTRAN and WiMAX in both directions.
- The evolved 3GPP system shall support the above mentioned mobility scenarios for UEs with single radio and dual radio solutions.
- The solution should have minimum impact on deployed WiMAX systems.

* 3GPP TR 36.938, Improved Network Controlled Mobility between E-UTRAN and 3GPP2/Mobile WiMAX Radio Technologies, V8.0.0, March 2008.

Handover Architecture*

- Architecture for optimized handover between mobile WiMAX and 3GPP access

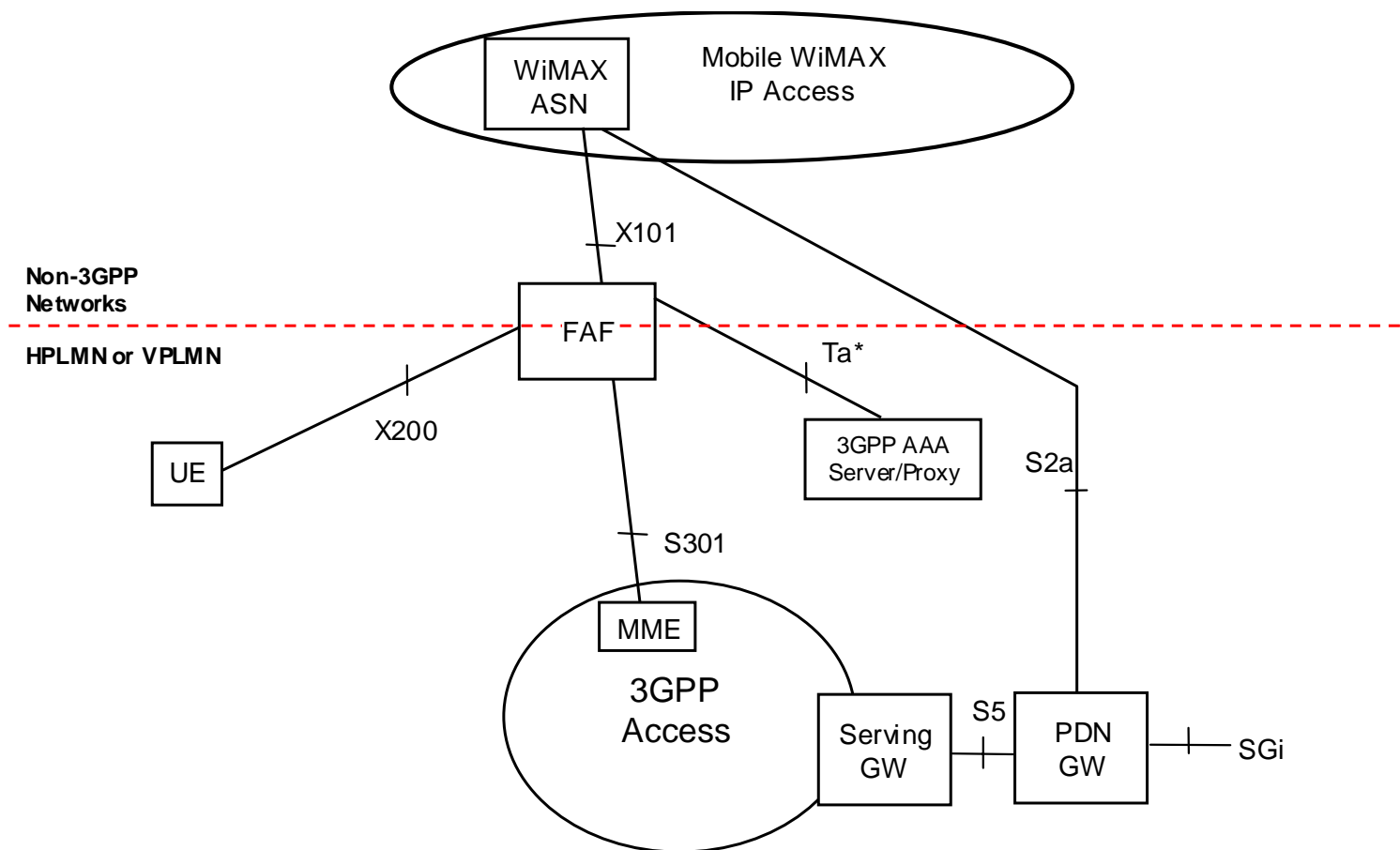

* 3GPP TR 36.938, Improved Network Controlled Mobility between E-UTRAN and 3GPP2/Mobile WiMAX Radio Technologies, V8.0.0, March 2008.

Handover Architecture – cont'd*

- Architecture for optimized handover between mobile WiMAX and 3GPP using L2 Tunneling

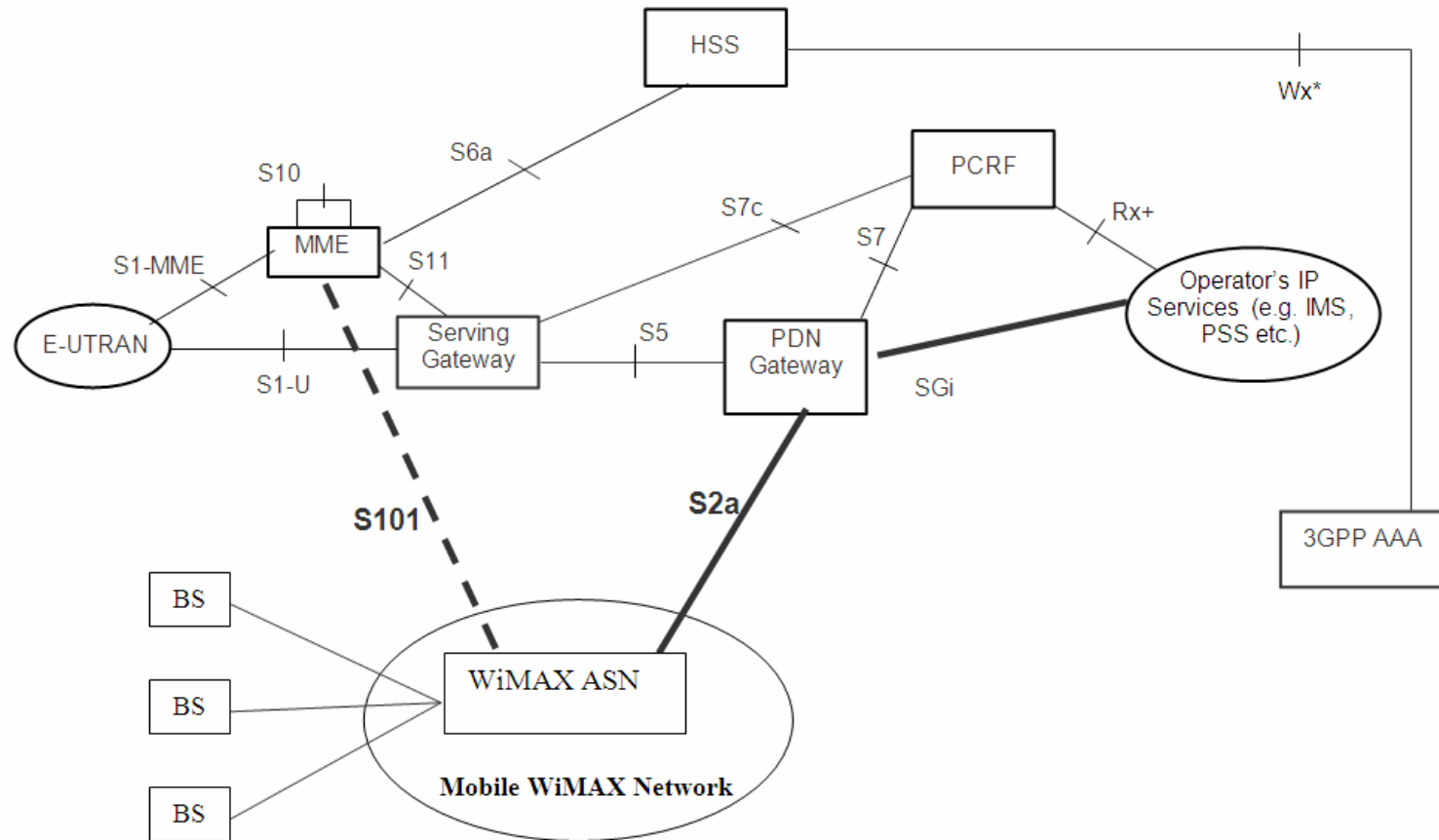

* 3GPP TR 36.938, Improved Network Controlled Mobility between E-UTRAN and 3GPP2/Mobile WiMAX Radio Technologies, V8.0.0, March 2008.

10 Handovers with Optimizations Between 3GPP Accesses and Mobile WiMAX

10.1 General Principles

The solution for network-controlled dual radio handover between 3GPP accesses (GERAN, UTRAN, E-UTRAN) and Mobile WiMAX is based on the concepts of clause 4.1.2, and in addition on the following principles.

- 1) The EPS shall support mechanisms for delivery of inter-system mobility, network discovery and selection policies over the Sx interface described in clause 4.8.
- 2) The policies shall contain information e.g. on availability of WiMax access networks that control the UE selection of available WiMax access network and the UE decision and triggering of 3GPP - WiMax handovers

Editor's Note: The definition of the exact semantic of the policies is work in progress.

- 3) The handover procedure will be executed according to the S2a/S2c procedures described in clause 8.

11 Handover Optimizations Applicable to All Non-3GPP Accesses

<This sub-section describes handover optimization procedures that are generic and applicable to all non-3GPP accesses. >

- Dual radio mobility will be considered in Release 8
Single radio mobility is pushed out to Release 9

Summary

Key Messages

- 3GPP LTE towards 4G
- 1-node RAN architecture common in the industry
- OFDM & OFDMA
- SC-FDMA (pros and cons)
- LTE Frame Structure, Slot Structure
- LTE Reference Signal & Synchronization Signal
- LTE Cell Search
- SAE to embrace all kinds of RAT

