

CDMA2000/ LTE Interoperability

CDMA2000/LTE Workshop - April 2009

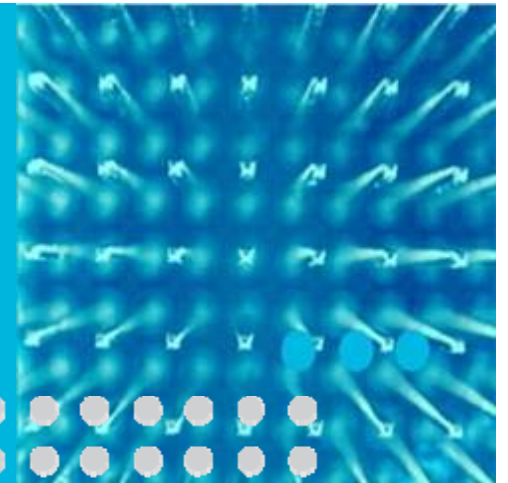

Joe Tarallo

Technology Director

Wireless Networks Product Division

jtalarlo@alcatel-lucent.com

(908) 582-0915

Agenda

1. LTE Overview: RAN & Evolved Packet Core
2. Deployment Flexibility: Adding LTE to CDMA Networks



1

LTE Overview: RAN and EPC

Technological description

A common future direction...

Long Term Evolution (LTE) is a complementary next-generation broadband wireless technology for all mobile operators

Enabling new applications, lowering cost



- Peer to peer applications requiring high throughput
- Online gaming
- Flat fee trend

facebook

OFDM

Robust modulation in dense environments

OFDMA (DL)/SC-FDMA (UL);
Increased spectral efficiency;
Simplified Rx design in UE for high speed data;
Scalable - from 1.4 MHz to 20 MHz carriers

MIMO

Increased link capacity

Multiple-input, multiple-output UL& DL;
Collaborative MIMO (UL);
Overcome multi-path interference

Flat IP

flat, scalable

Low latency via simpler bearer traffic handling;
Backhaul based on IP / MPLS transport;
Fits with IMS, VoIP, SIP

A taste of 4G...

...based on highly efficient technologies

LTE Network Architecture - A Flatter, All IP RAN and Core

2G/3G

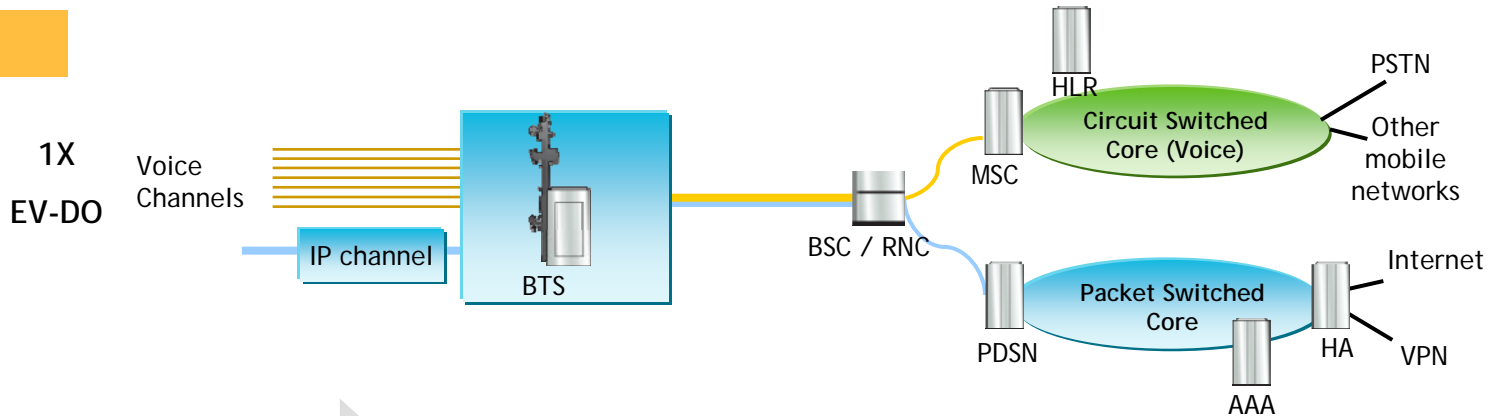

What is EPC ?

New IP based mobile core network introduced with LTE

- End-to-end IP Mobile Service Delivery Architecture
- New elements:
 - *Serving Gateway and PDN Gateway*
 - *Mobility Management Entity*
 - *Policy Charging Rules Function*
 - *HSS*

LTE+EPC

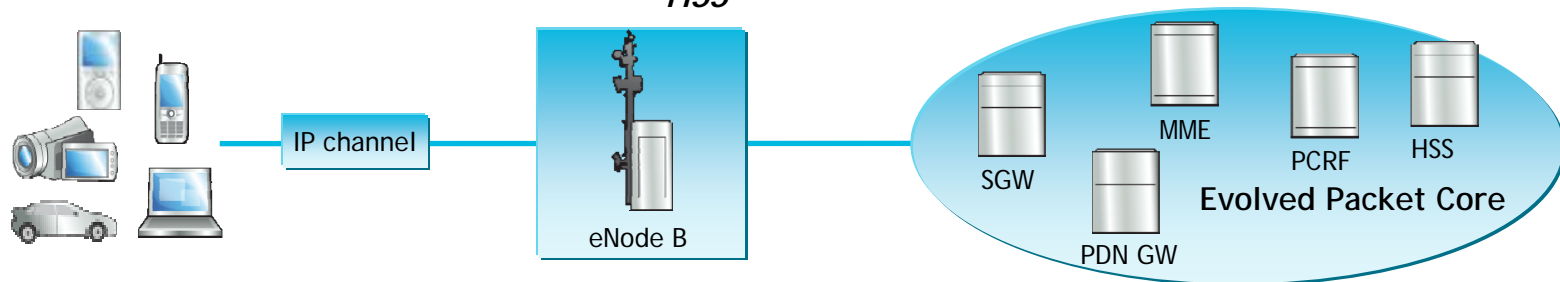

End-to-end IP transformation of mobile networks

All-IP mobile transformation: What happens?

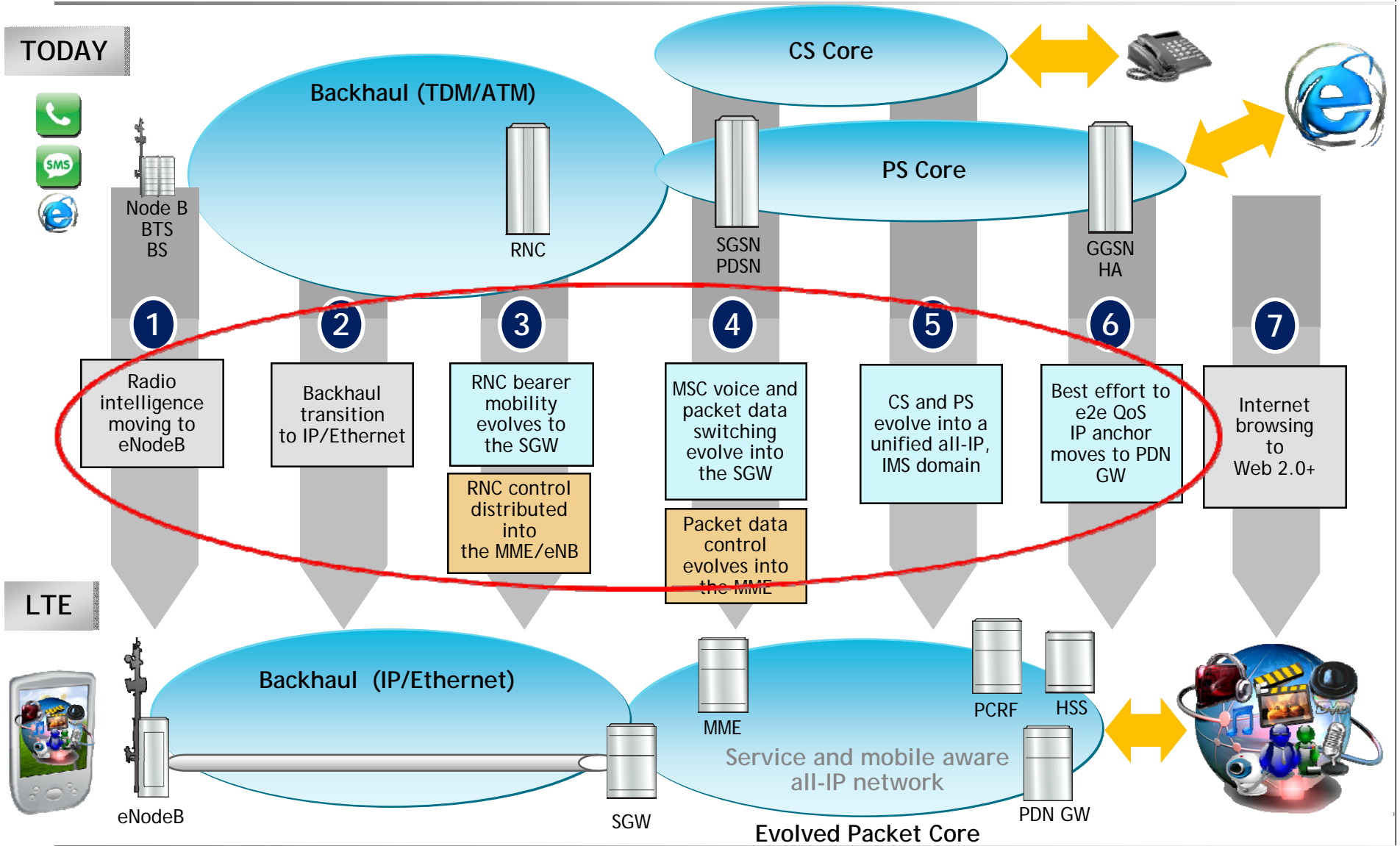

Serving Gateway (S-GW), Packet Data Network Gateway (PDN-GW), and Mobility Management Entity (MME)

S-GW is local mobility anchor

- Terminates (S1-U) interface towards E-UTRAN
- Local anchor point for inter-eNB handover and inter-3GPP mobility
- Support ECM-idle mode DL packet buffering and network-initiated service request
- IP routing and forwarding functions

PDN-GW is IP anchor for bearers

- Terminates (SGi) interface towards the PDN
- Provides UE IP address management (allocation)
- Provide Policy and Charging Enforcement Function (PCEF)
- Per-SDF based packet filtering

MME controls how UE interacts with the network via NAS signalling

- Authenticates UEs and controls access to network connections
- Controls attributes of established access (e.g., assignment of network resources)
- Maintains EPS Mobility Management (EMM) states for all UE's to support paging, roaming and handover
- Manages ECM (EPS Connection Management) states

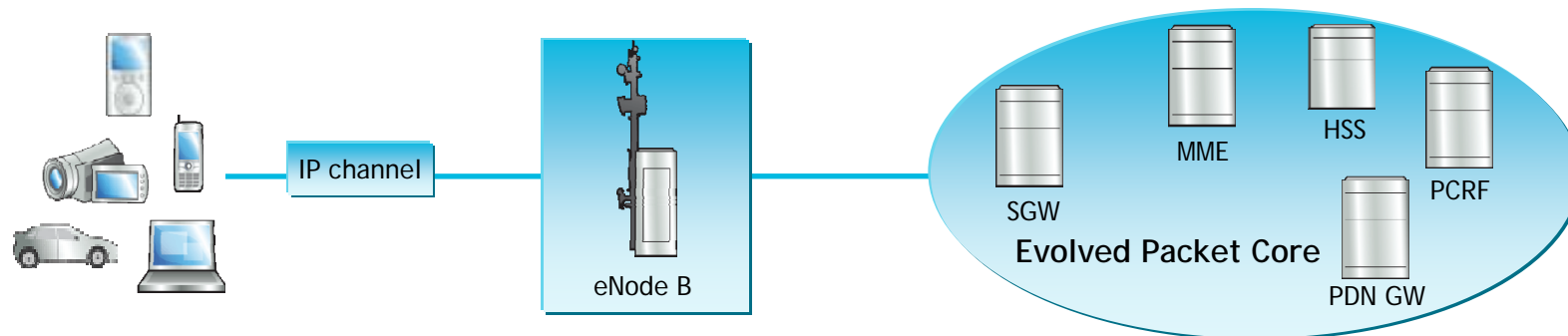

Converged E-HRPD & LTE Network Architecture

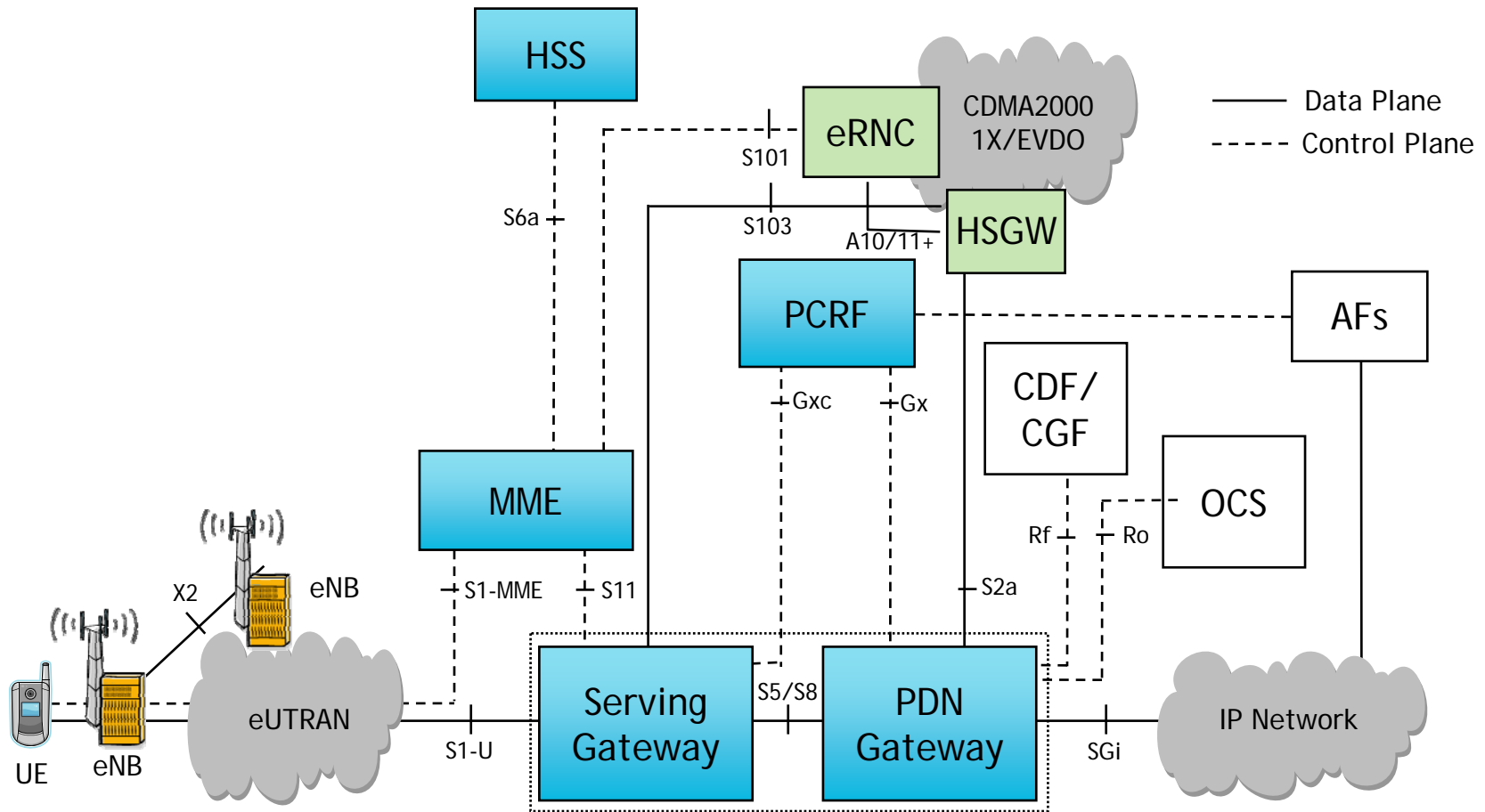



2

Deployment Flexibility:

Complementing CDMA Networks with LTE

CDMA to LTE Seamless Mobility: Value Proposition

- **CDMA/LTE Seamless Mobility will be critical for a successful LTE deployment**
 - LTE technology deployment will target high data traffic areas first
 - Users will continue to demand uninterrupted coverage
 - Interworking LTE with eHRPD (EV-DO) data and 1X voice maximizes ROI on all assets

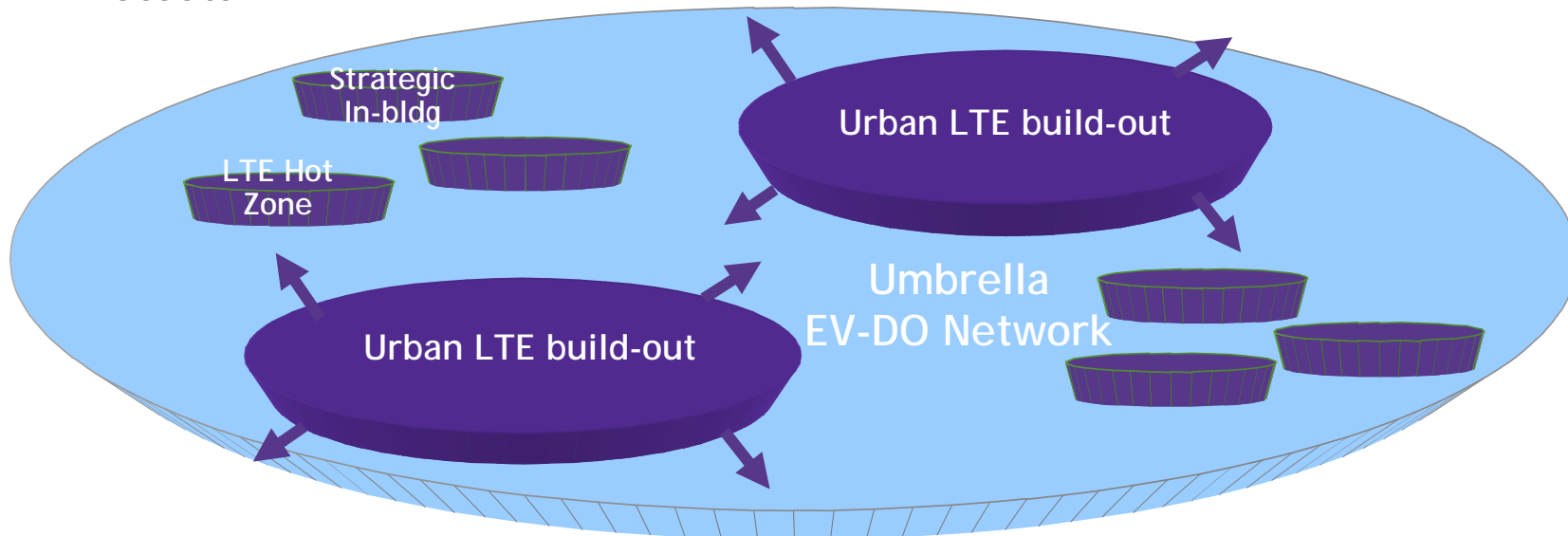

Evolved HRPD Enables seamless IP mobility between EV-DO and LTE:
Critical for mobile enterprise VPN services and "always on" user services

Interworking LTE with EV-DO via Evolved HRPD (eHRPD)

- eHRPD is an enhancement to traditional EV-DO (HRPD) to enable future seamless IP mobility with LTE based on 3GPP Standards for Evolved Packet Core (EPC)
- Moves the IP mobility anchor out of the Home Agent and into the PDN-Gateway
- Changes from a client-Mobile IP based IP Mobility model to Proxy Mobile IP
 - No more foreign agent
 - HSGW implements Proxy Mobile IP
 - Handset uses Simple IP
- Uses EAP-AKA' for User authentication
 - Instead of PAP/CHAP, EAP-AKA' conforms to 3GPP standards
- May optionally include IPv6 support
 - Enables larger IP address space for mobiles, and simplifies security
 - Supports multiple IP addresses per UE, with combination of IPv6 & IPv4

LTE to eHRPD Interworking

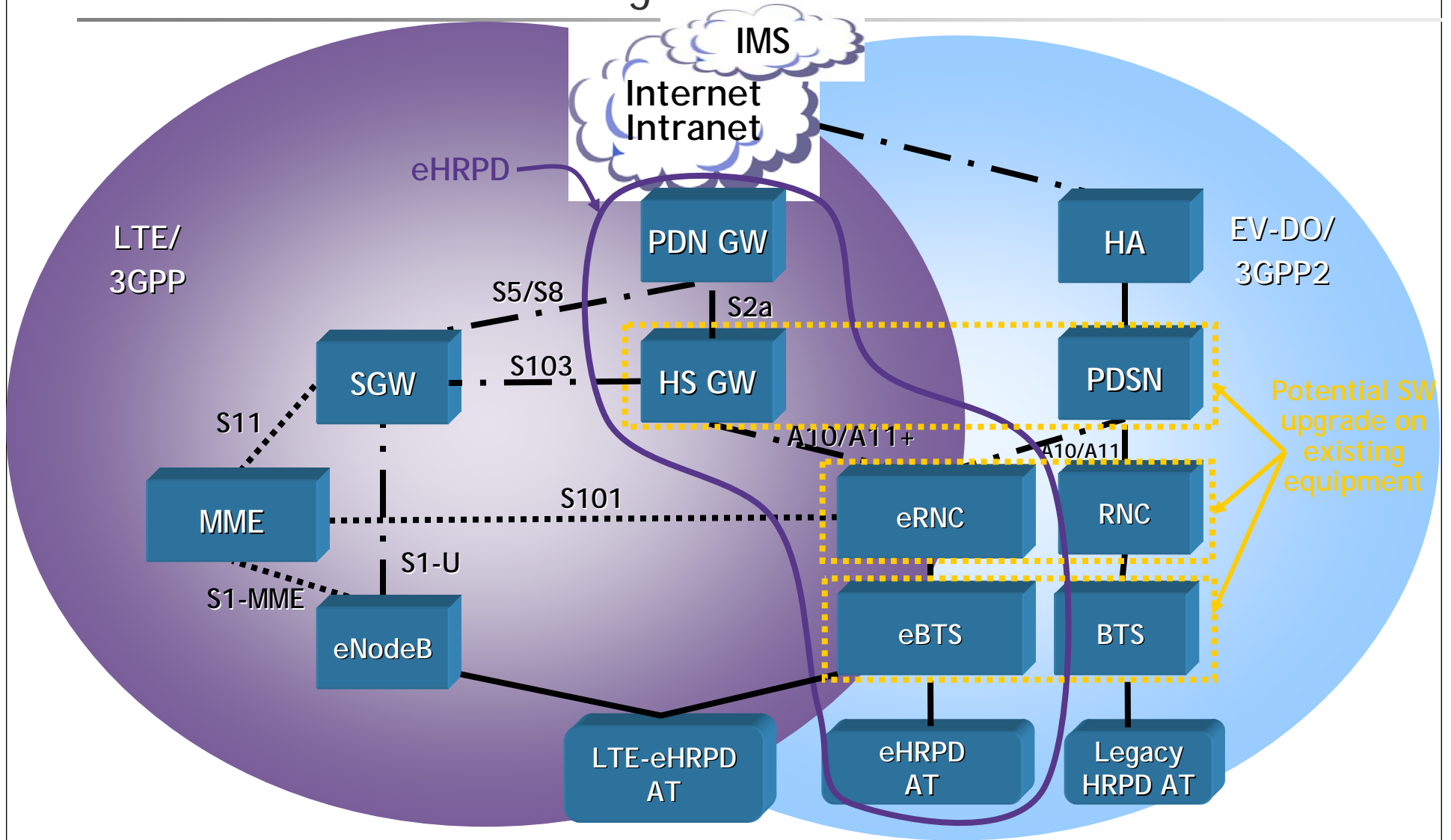

What about voice?

LTE only for voice *and* data?
Or LTE data and traditional 3G1x voice?

Factors to consider:

- How important is simultaneous voice & data?
 - How important is an all-IP service model?
 - CAPEX spending priorities?
 - Maximize voice capacity?
 - Roaming Partners?
 - Handset complexity?
 - Timing?

3G1x CS Voice?

LTE VoIP?

1X Enhanced?

EV-DO VoIP?

CDMA2000: Best Flexibility for All Voice Needs

LTE/1X Circuit Switch Fallback permits voice calls to get through even when on an LTE data session

Lowest cost, most efficient voice for "all you can eat" voice plans

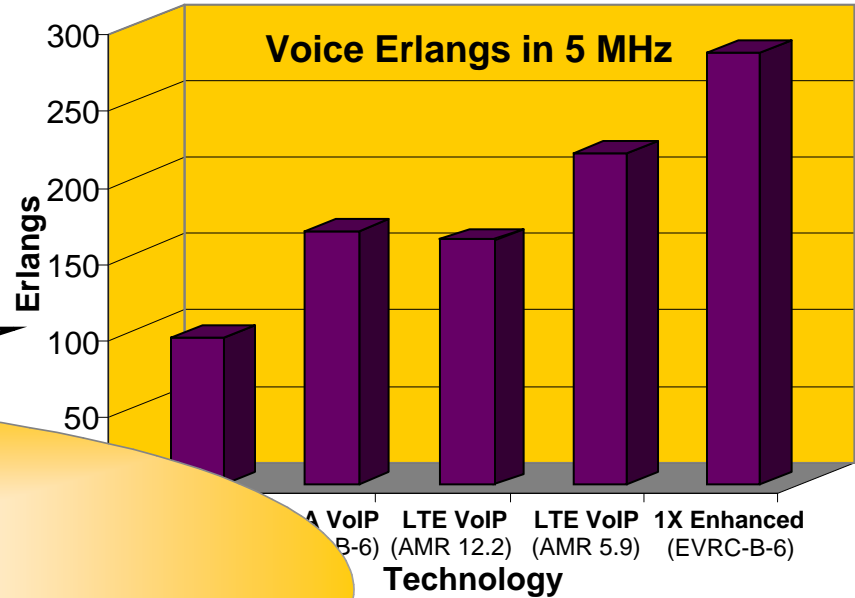

Full area coverage for 1X Voice

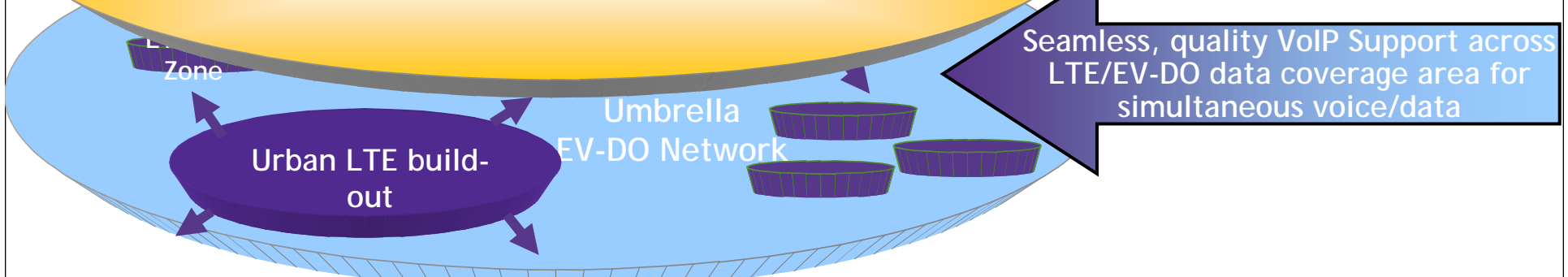

CDMA2000 1X has the highest voice capacity per Hz of any mobile technology out there, maximizing available spectrum available for broadband data, whether EV-DO or LTE

CDMA2000 1X: Best in Class for Voice Capacity

CDMA2000 3G1x voice capacity roadmap
is best in class:

- Enables more voice in less spectrum
- Maximizes available bandwidth for broadband data

3GPP & 3GPP2 standards enable
coexistence and interworking between
3G1x and LTE on handsets

- Circuit switch fallback - enabling voice to remain on 3G1x while data is carried on LTE
- LTE VoIP roaming and handoff to traditional 3G1x voice
- Both leverage "S102" interface between CDMA MSC & LTE ePC

CDMA2000 1X has the highest voice capacity per Hz of any mobile technology out there, maximizing available spectrum available for broadband data, whether EVDO or LTE

CDMA2000 1X and LTE Voice Interworking: Circuit Switch Fallback

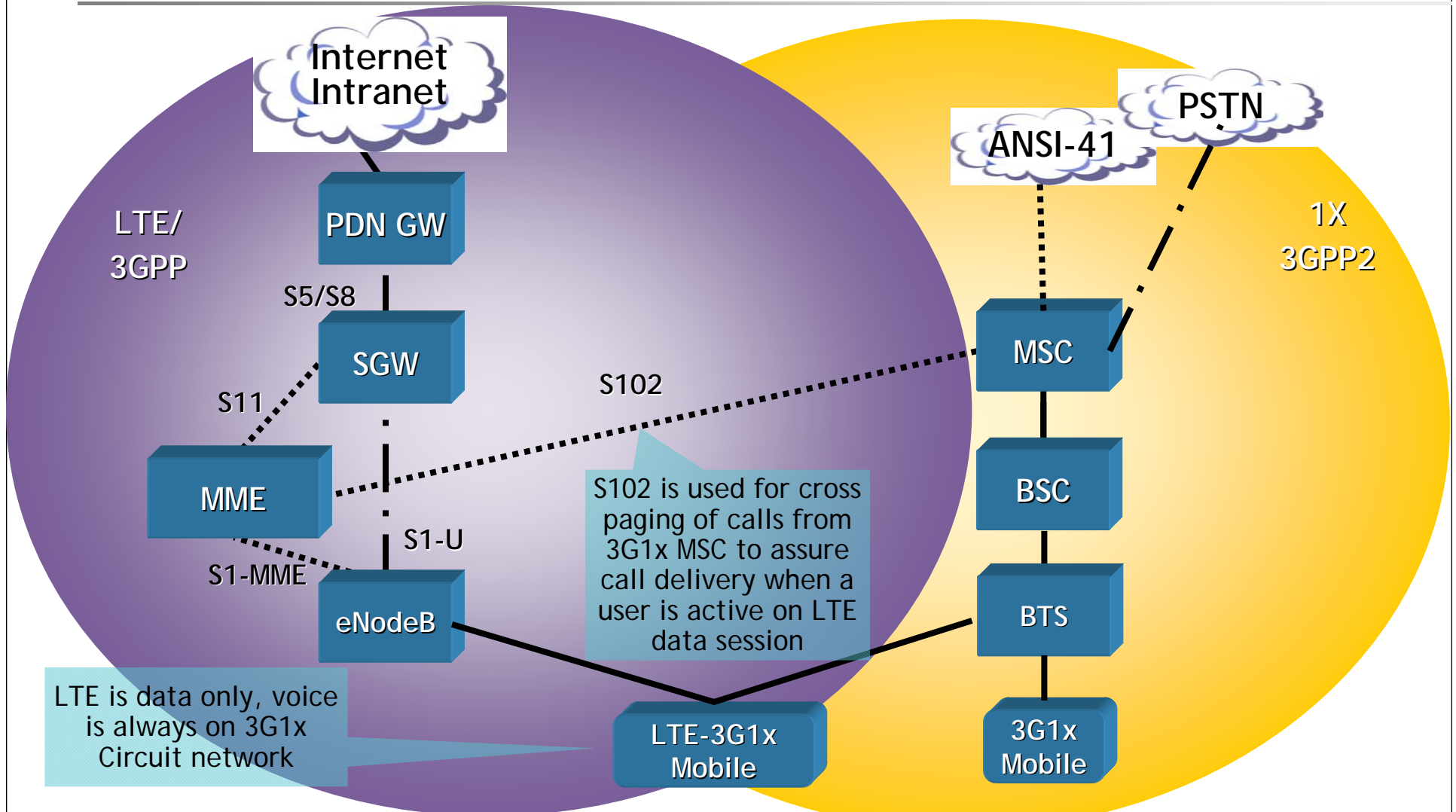

LTE is used for data only, and CDMA2000 1X circuit voice is used for all voice calls.
LTE coverage overlaps 1X coverage.

Alcatel-Lucent's Strength in CDMA and LTE

Large Customer Base

Committed to CDMA and LTE

Leading CDMA and LTE Innovation

Seamless Coexistence & Interworking Between CDMA & LTE

Unmatched Support

Unique end-to-end products and services commitment

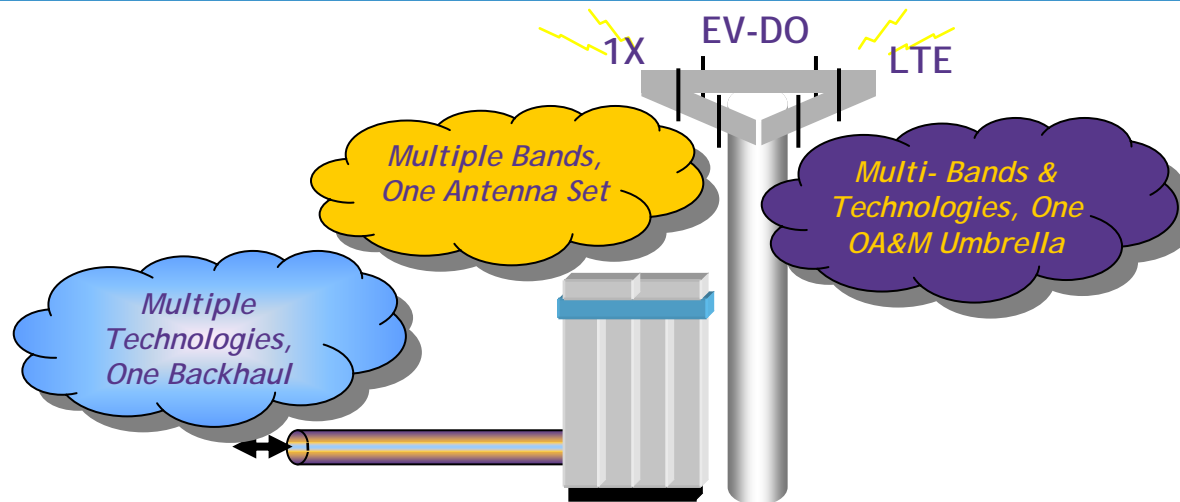

www.alcatel-lucent.com

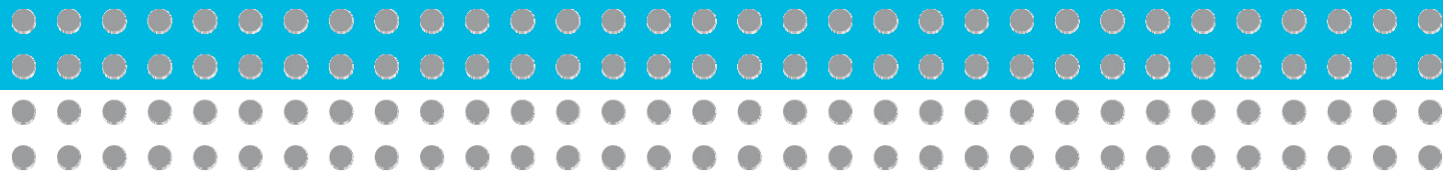

Acronyms



Acronym List

1X	CDMA2000 1X	BSR	Base Station Router	DCCH	Dedicated Control Channel
1X RNC	1X Radio Network Controller	BTS	Base Transceiver Station	DCS	Digital Cellular Switch
2G	2nd Generation (GSM, TDMA, Is95A)	BU	Binding Update (PMIP)	DHCP	Dynamic Host Configuration Protocol
3G	3rd Generation (CDMA2000, UMTS)	CAN	Connectivity Access Network	DL TFT	Downlink Traffic Flow Template
4G	4th Generation (LTE, WiMAX)	CapEx	Capital Expenditure	DL-SCH	Downlink Shared Channel
AAA	Activation, Authorization & Accounting	CBR	CDMA Baseband Radio	DNS	Domain Name Service
AAT	Average Aggregate Throughput	CCA	Credit Control Answer	DO RNC	1xEV-DO Radio Network Controller
ACK	Acknowledge	CCCH	Common Control CHannel	DPD	Digital Pre-Distortion
AF	Assured Forwarding	CCF	Charging Collection Function	DPH	Data Protocol Handler
AGW	Access Gateway	CCR	Credit Control Request	DPI	Deep Packet Inspection
aIMS	Advances to IP Multimedia Services	CCU	CDMA Control Unit	DRB	Data Radio Bearer
ALU	Alcatel-Lucent	CDF	Charging Data Function	DRC	Data Rate Control
AM	Acknowledged Mode	CGF	Charging Gateway Function	DSC	Data Source Control
AM	Application Manager	CDM	CDMA Digital Module	DSMIP	Dual Stack Mobile IP
AMBR	Aggregate Maximum Bit Rate	CDMA	Code Division Multiple Access	DTCH	Dedicated Traffic Channel
ANDSF	Access Network Discovery and Selection Function	CDMA2000	Brand for CDMA IS2000 (3G)	E	Erlang
ANR	Automatic Neighbor Relationship	cdmaOne	Brand for IS95A (2G)	eAN	evolved AN
AP	Application Processor	CHAP	Challenge Handshake Authentication Protocol	EAP- AKA	Extensible Authentication Protocol - Authentication and Key Agreement
APB	Active PhoneBook	cHDL	Cisco High Level Data Link Control	eAT	evolved AT
AR	Access Router	CI	Competitive Intelligence	eBTS	enhanced BTS
AR	Aggregation Router	CICC	Common Interface Control Card	ECM	EPS Connection Management
ARPU	Average Revenue per User	CMIP	Client Mobile IP	ECP	Executive Cellular Processor
ARQ	Automatic Repeat Request	CMU	CDMA Modem Unit	ECPC	ECP Complex
AS	Application Server	CN	Corresponding Node (MIP)	eCRTP	Enhanced Compressed RTP
ASIC	Application-Specific Integrated Circuit	CoA	Care of Address	EDGE	Enhanced Data Rates for GSM Evolution
ASN.1	Abstract Syntax Notation 1	CPG	Carrier Product Group	EDPD	Enhanced Digital Pre-Distortion
AT	Access Terminal	CPRI	Common Public Radio Interface	EF	Expedited Forwarding
ATCA	Application & Connection Control	cPSB	Compact Packet-Switching Backplane	eHRPD	Evolved High Rate Packet Data (aka EV-DO)
AWS	Advanced Wireless Services	CRC	CDMA Radio Controller	EIR	Equipment Identity Register
BA	Binding Acknowledgement (PMIP)	CRM	Customer Relationship Management (Siebel)	EMM	EPS Mobility Management (part of NAS)
BCCH	Broadcast Control Channel	CSCF	Call Session Control Function	EMS	Element Management System
BCH	Broadcast Channel	CSG	Closed Subscriber Group	eNB	evolved Node B
BCMCS	Broadcast Multicast Services	CTCH	Common Traffic Channel	eNodeB	evolved NodeB (LTE BTS)
BHCA	Bust Hour Call Attempts	CTU	Central Timing Unit		
BHL	Backhaul	DAD	Duplicate Address Detection		
BM	Bearer Manager	D-ARQ	Delayed ARQ		
B-PCF	1X RNC Blade PCF				

Acronym List (cont.)

ENUM	tElephone NuMbering Mapping	GW	Gateway	LI	Lawful Intercept
ePC	evolved Packet Core	H-ARQ	Hybrid ARQ	LMA	Local Mobility Anchor
E-PCF	Netra Ethernet PCF	HD	High Density	LMD	Local Mobility Domain
E-PCF	Netra Ethernet PCF	HDLC	High Level Data Link Control	LMRS	Lucent Media Resource Server
ePDSN	Evolved PDSN	HLR	Home Location Register	LNG	Lucent Network Gateway
EPS	Evolved Packet System or Service	HO	Hand Off	LTE	Long Term Evolution
ER	Edge Router	HoA	Home IP Address	MAC	Message Authentication Code
eRNC	evolved Radio Network Controller	HP-PTT	High performance Push-to-Talk (aka QCHAT)	MAC	Media Access Control
ERP	Enterprise Resource Planning (Portal. Focusing on SAP, Oracle, PeopleSoft)	HSD	High Speed Data	MAP	Mobility Anchor Point (MIP)
ESC	Ethernet Switch Card	HSDe	HSD (Enterprise)	MAP	Market Advantage Program
ESM	EPS Session Management (part of NAS)	HSDmm	HSD (Mass Market)	MAP	Market Advantage Program
eSM	Enhanced Service Manager	HSDPA	High Speed Downlink Packet Adapter	MBSFN	MBMS over Single Frequency Networks
e-UTRAN	Evolved UMTS Terrestrial RAN	HSDsmb	HSD (Small-Medium Business),	MCCH	Multicast Control Channel
EVM	1xEV-DO Modem for Modcell 4.0	HSGW	HRPD Serving GateWay	MC-EVM	Multi Carrier – EV-DO Modem
EVMm	1xEV-DO Modem for Modcell 1.0-3.0	HSGW	HRPD Serving Gateway	MCR	Multi Carrier Radio
FBP	Flexent Blade Platform	HSPA	High Speed Packet Adapter	MGCF	Media Gateway Control Function
FCC	Federal Communications Commission	HSS - Home Subscriber Server		MGW	Media Gateway
FMM	Flexent Mobility Manager	HSUPA	High Speed Uplink Packet Adapter	MI	Management Interface
FMS	Flexent Mobility Server	HUSP H	RPD-UE Signaling Protocol	MIB	Master Information Block
FPS	Flexent Packet Switch	HW	Hardware	MIH	Media Independent Handover
FRPH	Frame Relay Protocol Handler	IFRPH	ISDN Frame Relay Protocol Handler	MIMO	Multiple Input Multiple Output
FS	Frame Selection	IMEI	International Mobile Equipment Identity	MLG	Multi Layer Group
GA	Generally Available	IMS	IP Multimedia Subsystem	MLPP	Multi-Level Pre-emptive Priority
GEE	Generic EAP Encapsulation	IMSI	International Mobile Station Identifier	MLPPP	Multi Link Point to Point Protocol
GICC	Gateway Interface Control Card	IOS	Inter-Operability Standards	MLS	Multi Layer Switch
GPON	Gigabit-Capable Passive Optical Network	IOT	Inter Operability Testing	MME	Mobility Management Entity
GPRS	General Packet Radio Service	IP	Internet Protocol	MRCF&P	Media Resource Control Function &
GRAS	Global Roaming Application Server	IPBH	Internet Protocol Back Haul	MSC	Mobile Switching Complex
GSM	Global System for Mobile Communications	IPCP	Internet Protocol Control Protocol	MSCE	Mobile Switching Center enhanced
GTP	GPRS Tunneling Protocol	IPoHDLC	IP over HDLC	MTCH	Multicast Traffic Channel
GUI	Graphical User Interface	IS	Interim Standard	NA	North America
		ISG	Intelligent Services Gateway	NACC	Network Assisted Cell Change
		L1	Layer One (ISO Protocol Stack)	NAQ	Negative ACK
		L2	Layer Two (ISO Protocol Stack)	NAR	North American Region
		L3	Layer Three (ISO Protocol Stack)	NAS	Network Access Server & Non-Access Stratum
		LCP	Lucent Control Platform		

Acronym List (cont.)

NETLMM	NGW Network GateWay Network Based Localized Mobility Management	PMK	Pairwise Master Key	SA	Service Architecture
NMS	Network Management System	PP	Packet Pipe	SAE	System Architecture Evolution
OA&M	Operation, Administration & Maintenance	PS	Protocol Server	SB-CBR	Single Board Radio for Modcell 4.0
OCn	Optical Carrier n = 1, 3, 12 etc.	PSG	Packet Switch Gateway	SB-CBRm	Single Board Radio for Modcell 1.0-3.0
OCS	On-line Charging System	PSTN	Public Switch Telephone Network	SB-EVM	Single Board EVM for Modcell 4.0
OFDM	Orthogonal Frequency Division Multiplexing	PSU	Packet Switching Unit	SB-EVMm	Single Board EVM for Modcell 1.0-3.0
OMC-CN	Operations & Maintenance Center - Core Network	PTI	Protocol/Procedure Transaction Id	SCM	Supply chain management
OMC-H	Operations & Maintenance Center - Home Location Register	PTS	Push to Speak	SDB	Short Data Burst
OMP-FX	OMP for Flexent	PTT	Push to Talk	SDF	Service Data Flow
OpEx	Operational Expenditure	PTX	Peer Telephony eXchange (PTX) also known as Peer-to-Peer (P2P) call	SDM	Services Data Manager
OSA-GW	Open Service Access - Gateway	QAM	Quadrature Amplitude Modulation	SFA	Sales Force Automation (Siebel)
PA	Packet Adapter	QLIC	Qualcomm Interference Cancellation	SGW	Serving Gateway
PAP	Password Authentication Protocol	QoS	Quality of Service	S-GW	Serving Gateway
PC	Personal Computer	R&D	Research and Development	SHO	Soft Hand Off
PC	Power Control	R1SR	R1 Satellite Ready Frame	SIB	Signalling Information Block
PCF	Packet Control Function	RAN	Radio Access Network	SIP	Session Initiated Protocol
PCO	Protocol Configuration Option (for PMIP BA)	RAT	Radio Access Technology	SLAAC	StateLess Address AutoConfiguration
PCRF	Policy Charging Rule Function	RB	Radio Bearer	SM	Security Manager
PD	Packet Data	RCC	Reliable Clustered Computing	SMSC	Short Message Service Center
PDCP	Packet Data Convergence Protocol	RCS	Radio Cluster Servers	SNMP	Simple Network Management Protocol
PDF	Policy Decision Function	RCS	Radio Control System	SON	Self Organizing Network
PDN	Packet Data Network	Rev 0	1xEV-DO Revision 0	SRB	Signalling Radio Bearer
PDN-GW	Packet Data Network - Gateway	Rev A	1xEV-DO Revision A	SRVCC	Single Radio Voice Call Continuity
PDSN	Packet Data Serving Node	RLC	Radio Link Control	SS7	Signaling System 7
P-GW	PDN Gateway	RLP	Radio Link Protocol	SSH	Secure Shell
PHA	Protocol Handler for ATM	RNC-M	CDMA2000 1X RNC Management	S-TMSI	Serving Temporary Mobile Subscriber Identifier
PHV	Protocol Handler Voice	RNL	Radio Network Layer	SUA	Software Update Automation
PLMN	Public Land Mobile Network	R-OCM	Reverse Optical Channel Module	SVD	Simultaneous Voice & Data
PM	Policy Manager	ROHC	Robust Header Compression	SW	Software
PMIP	Proxy Mobile IP	ROI	Return on Investment	TA	Timing Advance
		RRC	Radio Resource Control	TAC	Tracking Area Code
		RRH	Remote Radio Head	TAI	Tracking Area Identity
		RSRP	Reference Signal Received Power	TAU	Tracking Area Update
		RSRQ	Reference Signal Received Quality	TCS	Traffic Control Server
		RTP	Real-time Transport Protocol	TDM	Time Division Multiplexing
		Rxx	Release xx = 28, 29, 30 etc.	TDMA	Time Division Multiple Access

Acronym List (cont.)

TMSI	Temporary Mobile Station Identifier
TNL	Transport Network Layer
TP	Traffic Processor
TPU	Traffic Processor Unit
TrFO	Trannscoder Free Operation
TS	Time Slot
UCR	Ultra CDMA Radio for Modcell 4.0
UCRm	Ultra CDMA Radio for Modcell 1.0-3.0
UDP	User Datagram Protocol
UE	User Equipment
UL TFT	Uplink Traffic Flow Template
ULAM	Ultra Linear Amplifier Module
UM	Unacknowledged Mode
UMB	Ultra Mobile Broadband
UMTS	Universal Mobile Telecommunications System
USDS	Universal Subscriber Data Structure
VCC	Virtual Channel Connection
VCVM	Virtual Cluster Virtual Machine
VoA	Visited IP Address
VOC	Vocoder
VoIP	Voice over IP
VPC	Virtual Path Connection
VPN	Virtual Private Network
VSNC	Vendor Specific Network Control Protocol
VSNP	Vendor Specific Network Protocol
W-CDMA	Wideband CDMA
WPS	Wireless Priority Service